

THE CALLBOARD

OF THE REDWOOD EMPIRE DIVISION



Visit RED at Website: <http://home.earthlink.net/~campgus/>

April – June 2007

All Railroad enthusiasts are welcome to enjoy an afternoon of model railroading fun on Saturday, May 19th.
There is no charge to attend.

May Meeting

Monroe Hall
Santa Rosa

The next meeting of the Redwood Empire Division will be held on **Saturday**, May 19 starting at 1 PM. The meeting is being held at Monroe Hall, 1400 West College Avenue in Santa Rosa.

A program on DCC will be presented by author Don Fiehmman. Don has written a number of product reviews and magazine articles, including a series of 24 articles about DCC in *Railroad Model Craftsman* starting in March 2001 and ending in February 2003. He will have a demonstration track with NCE equipment. In addition, GUS CAMPAGNA will have a HO/On30 switching layout featuring Lenz equipment. Test tracks for N, S, On3 and G gauge will also be provided, so bring your DCC equipped locomotive to demonstrate and/or discuss any problems you are having. Everyone will get a free door prize

ticket. If you are wearing your division name badge it will be worth an additional free ticket, as will bringing something for the contest display (see page 2) and/or at least one guest. Tickets can be purchased, three for one dollar, for two special door prizes, which will be an Atlas U23B lettered for Santa Fe and a book, *"Railroads Through The Coeur d'Alenes"* by John W. Wood.

A short RED business meeting will include a report on the state of our division and elections for division superintendent and chief clerk. See page 3 regarding the election ballot included in this CALLBOARD issue.

Plan to have lunch before arriving or bring a bag lunch with you. Coffee will be available. Sandwiches and

other snacks can be purchase at the G & G Market, which is located across the street from Monroe Hall.

Doors open at noon. Please do not come before then because a previous group meeting will be finishing up.

We hope to see you on Saturday, May 19 after 12 noon and before 1 PM.

Driving Directions

Monroe Hall is located in Santa Rosa on the south side of West College Avenue between North Dutton Avenue and Stony Point Road. Go **west** on College Avenue from Hwy 101. Vehicle parking is located behind the building.

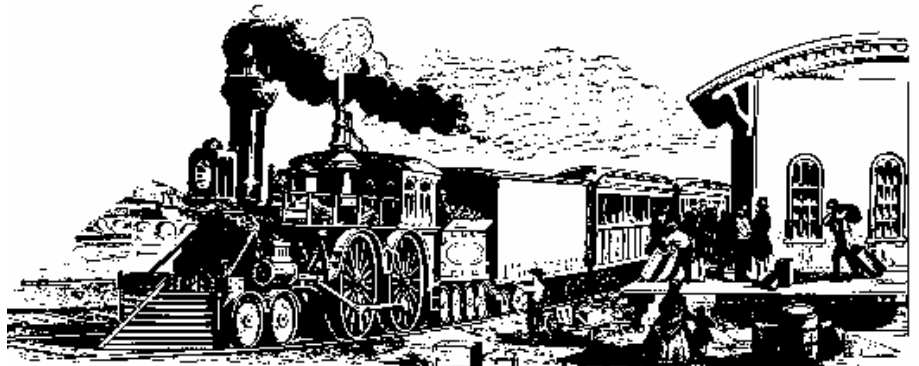

STAFF ROSTER**DIRECTOR**

Nolan Alexander
5307 Spain Avenue, Santa Rosa, CA 95409
(707)537-8108
E-mail: nolanalexander@msn.com

SUPERINTENDENT

Nolan Alexander
5307 Spain Avenue, Santa Rosa, CA 95409
(707)537-8108
E-mail: nolanalexander@msn.com

CHIEF CLERK

Steve Skold
5306 Yerba Buena Rd, Santa Rosa, CA 95409
(707)539-1782
E-mail: sandcaskold@aol.com

CONTESTS

Steve Skold
5306 Yerba Buena Rd, Santa Rosa, CA 95409
(707)539-1782
E-mail: sandcaskold@aol.com

MEMBERSHIP

Gus Campagna
PO Box 6344, Santa Rosa, CA 95406-0344
E-mail: campgus@earthlink.com

NOMINATIONS

Ed Zakareckis
2408 Homestead Court
Fairfield, CA 94533-7137
(707)425-1159
E-mail: ezak@castles.com

ACHIEVEMENT PROGRAM

Harold Mentzer
102 Berna Avenue, Napa, CA 94559
(707) 226-5153
E-mail: hsmmentzer@aol.com

ESTATE COUNSELOR

Don Clauder
305 Garfield Park, Santa Rosa CA, 95409
(707) 539-3510

CALLBOARD EDITOR

John Rolston
240 Chase St., Sonoma CA, 95476
(707) 938-5478
E-mail: jrolston@pacbell.net

**CHIEF CLERK'S
REPORT**

BY STEVE SKOLD

RED's winter meeting was held on February 24th at the Napa Model Railroad Club. There were 18 people in attendance. First, business was conducted to accept nominations for the positions of Superintendent and Chief Clerk/Paymaster. STEVE SKOLD was nominated for Superintendent and ED MERRIN for Chief Clerk. GUS CAMPAGNA then resigned as Director. NOLAN ALEXANDER was nominated and elected to fill the remainder of Gus' term as Director, which expires in 2008.

RON PLIES did a clinic on researching the Northwestern Pacific Railroad and using the research for modeling. He belongs to the Eel River Valley model railroad club which is doing the NWP in modular form. GUS CAMPAGNA followed up with a power point presentation on NWP buildings that could be easily modeled. The final part of the program was the video by Paul Scoles on Advanced Scenery Techniques.

The Napa Club had several members operating their layout and discussed their upcoming conversion to DCC. It will be interesting to see how that conversion works out.

We are still looking for a volunteer for meeting contests. This month, the contest will be a show and tell of contest models our members took to the PCR Convention in Santa Cruz. This includes photos.

I hope to see a lot of you in May at both the PCR convention and RED May 19th meeting.

**From DIRECTOR &
SUPERINTENDENT**

NOLAN ALEXANDER

It's time for me to pass my job as Superintendent to someone else and I wanted to thank the members of the Redwood Empire Division for the opportunity to serve. I suppose that this is also a good time to say thanks as well, for the opportunity to serve now, as your RED Director. I'm looking forward to my first Board meeting at the convention in Santa Cruz and I hope that I'll see you there as well.

I heard from a convention committee member that the pre-registration for this event has gone very well and it should be a lot of fun with so many activities planned. This should be really nice for me; I've attended quite a few conventions, but only twice where I wasn't a member of the host committee. I am especially looking forward to getting out on some layout tours.

Before I get too much into Director mode, I do want to say, "Thanks" to STEVE SKOLD for supporting me as Chief Clerk during my tenure as your Superintendent. Also a big thank you to JOHN ROLSTON for taking care of the Callboard. John has kept me on schedule with his deadlines and welcome reminders. Also, thanks to GUS CAMPAGNA, DON CLAUDER, ED ZAKARECKIS, HAROLD MENTZER and all the others who did their jobs so well that my job was easy.

I'm looking forward to working with the new President of the PCR and the Board to keep our organization going and to find ways to serve the membership. If you've got any ideas along those lines, complaints, or just want to grind your axe,

(Continued on page 3)



(Dir. & Supt. Report Cont'd. from page 2)

please contact me. My email address and other contact information is listed on page 2.

Happy railroading !



ANNUAL MEETING OF THE REDWOOD EMPIRE DIVISION

Date: June 3, 2006.

Call to Order Time: 1:02 PM

1. APPROVAL OF MINUTES of the last meeting, as published in the 4-6/2005 CALL BOARD. Moved, seconded and passed unanimously.

2. TREASURER'S REPORT by Chief Clerk Steve Skold.

Total 2005 Income:	\$224.00
Total 2005 Expenses:	\$826.93
Net loss for 2005:	\$602.93
Current cash balance:	\$2371.75.

OTHER COMMITTEE REPORTS

Gus Campagna was elected as RED's Director to the PCR Board.

OLD BUSINESS None

NEW BUSINESS

RED's next turn to put on a PCR Convention is 2010. No one stepped forward to volunteer as chairman.

John Leins resigned as coordinator of the Apple Blossom Fair RED display.

DIRECTORS REPORT: Gus Campagna talked about PCR's lack of support for the Divisions and for the PCR Branch Line newsletter. Nominations are being requested for President and Vice-President of PCR.

ADJOURNMENT TIME: 1:09 PM

NOMINATIONS REPORT BY ED ZAKARECKIS

A ballot is enclosed for RED members with this CALLBOARD issue. Please follow the instructions on the ballot and either return it by mail or bring it to the May 19th RED meeting and submit it **before** the business meeting starts. Election results will be announced during the business meeting.



CLASSIFIED ADS

CLASSIFIED ADS

This is where we run classified ads from members and non-members. There is no charge for Redwood Empire Division members to place an ad. Non-members will be asked to pay a nominal charge of \$2.50 for each 4 lines.

**YOUR
FOR SALE
OR WANTED
ADD
GOES HERE**

EDITOR'S NOTES

Future CALLBOARD schedules are:

**July – September CALLBOARD
Staff Meeting:** 7:30 PM, July 17
Text Deadline: July 24
Mailing: July 31
Meeting: Saturday, August 18

**October – December CALLBOARD
Staff Meeting:** 7:30 PM, October 16
Text Deadline: October 23
Mailing: October 30
Meeting: Saturday, November 17

Submit all articles, calendar items, adds, comments and corrections to the Editor.

Attention CALLBOARD readers:

Please advise if you are willing to read future newsletters on-line at the RED website (vs. reading a printed mailed copy). Any or all pages can be printed by you at any time.

We've started a notification list to advise, by email, when future issues are available at the website.

Please send your "ok" by email to the Editor at: jrolston@pacbell.net. List "Yes Notification" on the email subject line. No message is required **except** your first & last name. Send it again IF your email address ever changes.

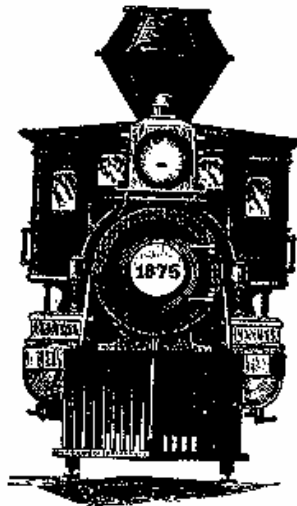

THINK SMALL #52

That Special Boxcar

I pulled Dunscomb's "Century of SP Steam Locomotives" off the shelf to browse the pictures of cross compound twelve wheelers. The single fat cylinder on the right side is a characteristic that rings my bells for some strange reason. The Bodega Western has 4-8-0 number 315 with a BIG low pressure cylinder on the right side that proves my strange quirk.

Dunscomb's book has a miscellaneous section at the back. On page 451 there is a picture of a big herald SP boxcar designed for "Think Small" folks. With a magnifying glass, I could read the letters stenciled on the side above the B-end truck: "27 FEET INSIDE". The external length of this boxcar's body would be just about 28 feet-REALLY SHORT for a standard gauge house car. I HAD to have a model of this car on my railroad. Clover House has lettering for several big herald SP boxcars. I checked the catalog. By golly, lettering set #8148-20 is for the very car pictured in Dunscomb's book. Lettering is available but the only way to put a model of that perfect THINK SMALL boxcar on Bodega Western rails would be to do a bit of scratch Building- an almost extinct part of model railroading for most of us. The workbench had been dusty too long! Building a boxcar or two would be refreshing. I had a project.

The plain old wooden boxcar was the work horse of the railroads from the 1840s to the 1940s. Some were still doing a job thirty or more years later. If you model standard gauge up to the early diesel era, you need another wooden boxcar -perhaps three more. If you are smitten with narrow gauge fever, look through your references for a boxcar that tickles your fancy. I have a different

way for you to scratch build a car you can couple into a local freight to show off your talent. HO is my scale but this method will certainly work for you S and N scalers as well. For me, the American Railroad Freight Car, Fig. 3.45 on page 231 was a handy reference. It is a 28 foot car. When I saw just two truss rods the deal was sealed. Us THINK SMALL folks are minimalists.

The Bodega shop's method for scratch building boxcars is probably different from yours. I start with a

block of wood -1/2" to 3/4" thick. Trucks, couplers and under body details are attached to the wood block. The body (sides, ends, roof, doors etc.) is a slipcover that hides that ugly hunk of wood. The method may seem strange but stay with me, you may like it. You may have different "druthers" for the boxcar you want on your rails. The drawings for this project look a bit different -they are flexible dimension wise. When you find a scale drawing for a car you like or you apply a scale rule to a favorite plastic car in your

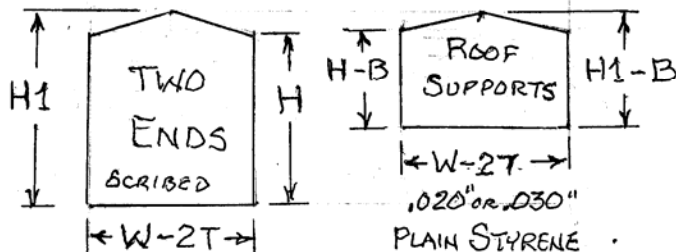
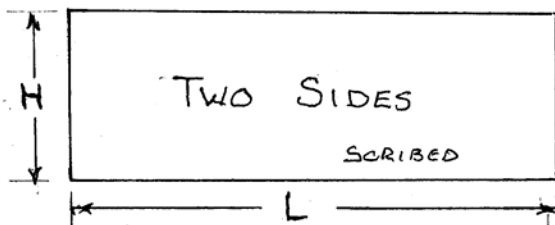
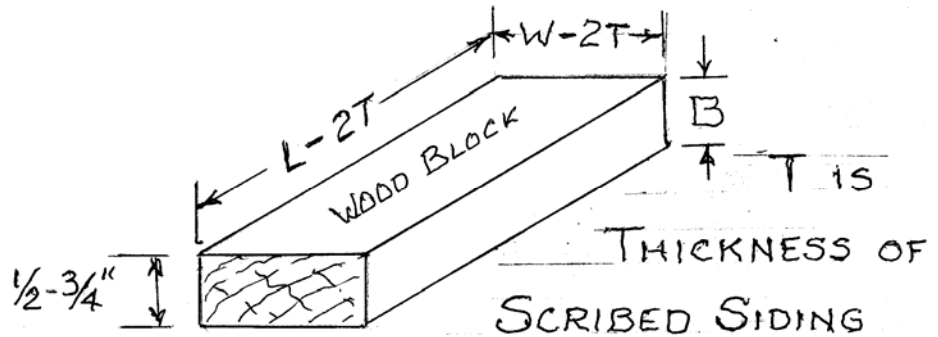
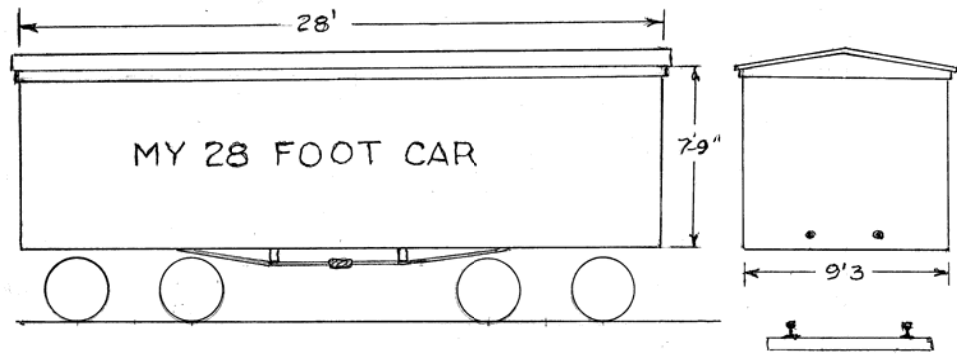

(THINK SMALL Continued from page 4)

fleet, you can determine the values of L, W, H, etc. My goal is to tease you into a bit of model building; not to push my choice of boxcar. For your car you will need a picture and some basic dimensions or a scale drawing or a car to copy, plus decals or dry transfers that go with your car. Also, a hunk of wood, trucks, couplers, K brake casting, staff brake wheel, some fine straight wire, styrene (plain, scribed and strip). A tomato can lid, sewing thread, brads, a bit of stripwood and some lead or pennies may be part of the mix.

The wood block can be plywood or smooth and fine grain pine or redwood. It better be square and true to your dimensions. Use a table saw or equivalent. Measure twice before you cut -then check. The wood block is the key to this method. Thickness is flexible; half to three quarter inch is fine. Start with a piece big enough to be safe on a power saw. Cut a strip to the desired width then cut to length. Your fingers are valuable -be safe) Sand off any fuzz, then sneak into the kitchen and borrow that handy can of cooking spray. Give the sides, top and ends of your block a light misting of oil and rub it in with your fingers. The slip- cover will need to slip on and off as the job progresses. Avoid getting any oil on the bottom of the block. Cut ten triangle braces from .020 to .040 plain styrene. Using your measurements for L, W, H, etc. cut the sides and ends for your car from freight car scribed styrene (#2037). Those minuses on the drawing for the end are important! Set your block on a metal or glass work surface and tack weld a side to an end. Just a small amount applied with a narrow brush will do the job. Next, weld the other side to the same end. The block makes it easy

to keep the parts square and aligned. Weld the other end in place and the basic box is defined. Wait a bit, then ease the block out from between the sides and ends. You may want to use another squirt of that cooking spray. Slip the sides and ends back on the block and return the assembly to the smooth work surface. Now weld corner braces set flat on top of the block into each corner. From .020 or .030 styrene, cut 3 roof supports (2 will do for a 28' car). Free the block if it is stuck in the corners, then put it back inside and weld the roof supports. The top view will look like this. The areas marked with "W" are where you can stick some pennies if your car needs a bit more weight. I count pennies at about 1/10 ounce each. Set your block, trucks, couplers and any



TOP VIEW OF STYRENE SHELL

castings you plan to use on a postal scale. Allow one ounce for the styrene slipcover, then add pennies or bore holes in the wood to achieve a car with a calculated weight close to the standard of one ounce plus 1/2 ounce for each inch of car length.

That block of wood needs a rest. Set it aside.

The body shell of your car needs a roof. In the picture, my 28 foot car's roof looks thin, so sheet metal over a single layer of boards tops my model. Translation: plain styrene with bumps a tad less than three feet apart where the metal sheets were joined. The method: scribed grooves with a bit of sewing thread glued in the slot.

A more common roof was the double board roof laid across the car. When the boards dried and shrunk, the resulting parallel gutters escorted the rainwater to the side of the car and the cargo stayed dry. Styrene

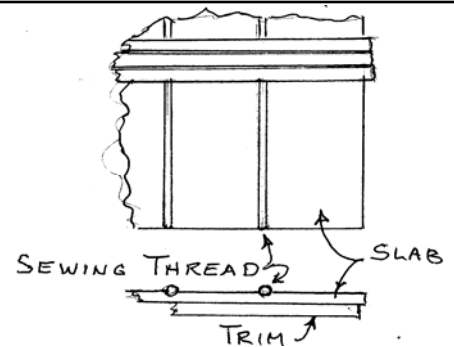

scribed 0.060" (#2060) looks about right for HO and saves a bit of



work.

Two slabs make the roof. To avoid regrets, cut them a bit oversize. You will be adding trim at the eaves; extra overhang is good insurance. A few minutes with a file or sanding block beats ripping off the roof and starting over.

Place a slab on your body-shell with one long edge extending over the side about 3 scale inches. If you have cover for added trim at the side and both ends, tack weld the slab in place. Do the same with the other slab. A slight gap on the center line

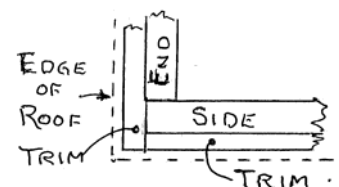
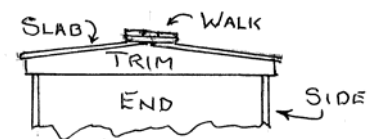
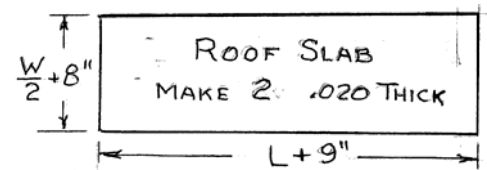

is ok; the roof walk will cover it. Now, dip a longer brush into the

(Continued on page 6)

(THINK SMALL Continued from page 5)

plastic weld and marry the roof slabs permanently to sides, ends and roof supports. Whether your roof is made of wood or metal, you will need a roof walk.

The length of .015 or .020 styrene scribed to represent three boards needs wedges of .020 styrene to support it at the roof's peak. Cut

workable bits of strip and weld them to the underside of the walk as shown. Then when the bond is firm, use a # 17 blade to chop them flush with the edge of the walk and bevel the inner ends. Try the walk on the roof. You may need to shave a bit more bevel. When the walk sits level, a generous application of that liquid plastic weld will give you a strong junction at the roof's peak.

Your slip-cover is now a sturdy little rascal ready for doors, staff brake wheel and other detail parts plus grab irons. That wood block sitting on your workbench will provide some interesting variations you may want to try. However, this essay is in two parts.

In the next CALLBOARD, you'll find part B of this sales pitch. My 28 foot boxcar is on the layout and rolling so I know this stuff works.

Bill Williams The Ancient One

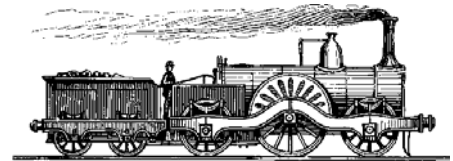
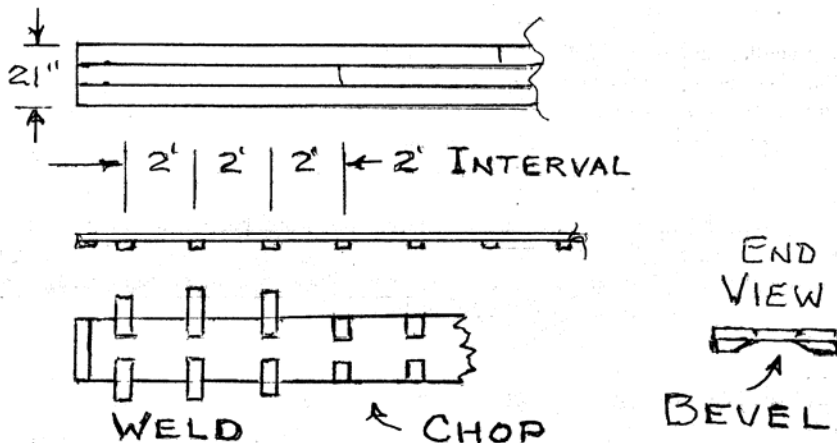

Redwood Empire Garden Railway Society (REGRS), No. 1 gauge, various scales. If you are interested call Ken Brody at (707)526-0195 or email westie@sonic.net

Napa Valley Model Railroad Historical Society, HO layout. Meets Fridays 7:30 PM at Napa Fairgrounds, 575 Third St., Napa. For information call: Clubhouse (707)253-8428 or Ron Rogers (707)224-4040 or John Rodgers (707)226-2985. www.nvmrc.org

Lake County Model Railroad Club, HO layout. Meets Wednesday at 7:00PM in the old National Guard Building at the Lake County Fairgrounds on Martin Street, Lakeport. Call Mike Ernst at (707)263-4949

Coastal Valley Lines, HO modular. Meets 1st Thursday of the month at 7:00 PM at Sam's For Play Café, 2630 Cleveland Ave., Santa Rosa. Call Brad Squires (707) 568-4298 or Don Hanesworth 823-9615

<http://cvl.hobby-site.com/>

Sonoma County Model Railroad Soci-

CLUB SCHEDULES

etym (SCMRS) is looking for members to help create a large permanent HO scale model railroad display to be located in Sonoma County. Modeling items are currently stored at the historic Healdsburg Railway Depot building. Contact Dave Gibbons at (707)526-2057 or email rrgibbons@sonic.net

NPC Operators. An On3 operating group meets one Sunday each month. Contact Steve Skold (707)539-1782 or email SandCSkold@aol.com

Redwood Empire Live Steamers. A new group is forming with the goal to build a 7 1/2 inch track facility in a local park. For information, call Don or Ann Bruner Welch at (707)578-4414 or write to PO Box 4594, Santa Rosa, CA 95402 www.redwoodempirels.org

Bay Area S Scalers. Contact Lee Johnson at (925)943-1590.

Mendocino Coast Model Railroad &

Historical Society, a Fort Bragg area group that promotes the hobby of model railroading. This group meets the 3rd Saturday of each month. At present, HO modules are being constructed. Contact Phil Miller at (707)937-3605 for more information.

North Coast Live Steamers, a group, from the Fort Bragg-Willits area, that promotes the hobby of large-scale railroading and other steam related history. Contact Bill Shepard at (707)961-0329.

Eel River Valley Model Railroaders, HO Scale layout. Meets each Friday evening at 7:30 P.M. at the Humboldt Co. Fair Grounds, Ferndale, CA. Write to P O Box 950 Fortuna CA 95540 or contact Ron Plies at (707)725-9063 or email rlplies@cox.net for more information.

www.eelrivervalleyrr.org

Humboldt Bay & Eureka, HO layout, Eureka, CA. Contact David Berriman, PO Box 915 Arcata, CA 95518. (707)825-7689.

COMING DOWN THE LINE

NWP Centennial Exhibition Schedule:

April 4-June 30: Fortuna Depot Museum, 3 Park St. Street, Fortuna

April 20-July 29: Western County Museum, 261 South Main Street, Sebastopol Th-Sn 1-4

June 1-Sept. 2: Mendocino County Museum, 400 Commercial St., Willits W-Sn 10-4:30

Aug. 1-Nov. 2: Clarke Historical Museum, 240 E St., Eureka Tu –Sat 12-4

Aug. 11-12: Heritage Days, Railroad Square, 15 Third St., Santa Rosa

May 5-6, June 2-3, July 7-8, Aug. 4-5: **Redwood Empire Live Steamers** will be running at Youth Community Park, 1725 Fulton Rd., Santa Rosa, across from Piner High School #

May 14: **Whistlestop North, NWPRRHS** presentation in Santa Rosa. <http://nwprrhs.org/>

May 19: **RED** meet in Santa Rosa. See page 1 for details

May 19-20 & July 28-29: **Sturgeons Sawmill** in Sebastopol, CA is once again running on steam! www.sturgeonsmill.com/

May 27, June 24, July 29, August 26: **Redwood Empire Garden RR Society** meetings. #

June 3: **Coast Division** Meet, San Mateo

June 8-9: **HOn3 Symposium** in Occidental www.hon3symposium.com/

June 23-24: **Coastal Valley Lines** run, Spring Lake Village, Santa Rosa #

August 18: **RED** picnic meet at the Western Railway Museum, Suisun City

November 17: **RED** meet in Santa Rosa

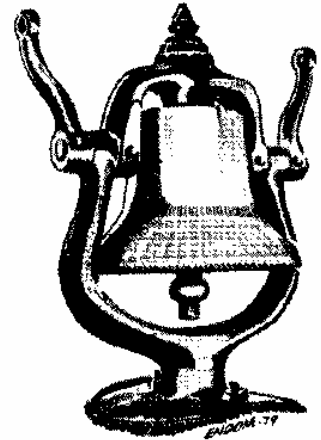

Many of the art items used in this newsletter are courtesy of Ken Houghton Rail Images or came from the web site: www.rrhistorical.com

Contact information is listed on page 6

Visit RED at Website: <http://home.earthlink.net/~campgus/>

CALLBOARD

John Rolston, Editor
240 Chase Street
Sonoma, CA 95476

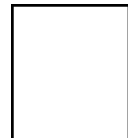

FIRST CLASS