

## INERTIAL MEASUREMENT UNIT ISIS-IMU

### Features

- Fully compensated Inertial Measurement Unit (IMU)
- Versatile output. (Analog and/or Digital)
- Most cost effective IMU - Lowest cost 6 degree of Freedom IMU in its performance class
- High angular rate capability (upto 3,000 °/ sec)
- High acceleration (upto 500 g)
- Inherent high ruggedness
- Small, lightweight and Low power consumption
- Comprised of Solid-State sensors (no moving parts)

### Typical Applications

- AHRS - Attitude Heading Reference System
- Vertical Reference System
- GPS/INS Applications
- Stabilization
- Tactical Missile navigation

### Block Diagram of ISIS-IMU

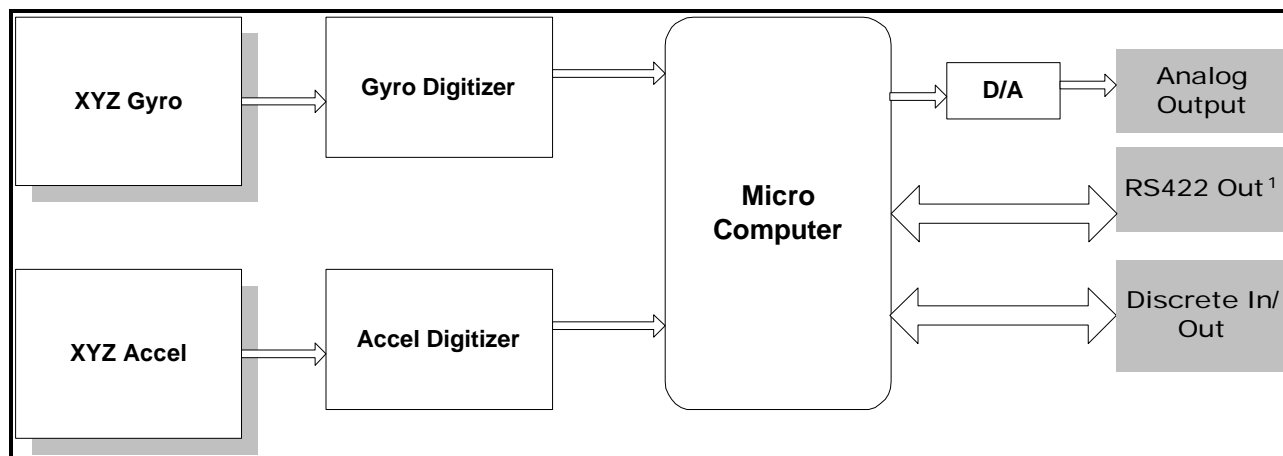

### Description

**ISIS-IMU** is a six-degree of freedom inertial measurement unit. ISIS achieves unparalleled price/performance and inherent ruggedness. It is well suited for medium accuracy and high dynamic environments, where small size (3.30" x 2.5" x 1.83"), lightweight (nominal weight is less than 250 gram), and low power consumption (less than 4W @ 5V DC) demanded. (E.g. smart weaponry, GPS integration, etc.).

It consists of three **RRS75** (solid state rate sensors) and three solid state accelerometers. This system incorporates a sigma-delta digitizer and a 16-bit microprocessor to provide fully compensated digital (RS422) and analog outputs.

ISIS can be configured to match customer's scale factor and bandwidth requirements. Inertial Science, Inc. can readily custom tailor this IMU to meet specific application requirements on a special order basis.

# Specification

ISI

<b>Size</b>	3.30" x 2.5" x 1.83"
<b>Nominal Weight</b>	< 250 gram
<b>Supply Voltage</b>	+/- 5V DC (+/- 0.3V) or +12V DC
<b>Nominal Input Power</b>	< 4 W @ 5V DC
<b>Rate Sensor (Each of 3-axis)</b>	ISI RRS75 (DC-IN, DC-OUT)
<b>Full Scale Rate</b>	+/- 3000 °/sec max.
<b>Bandwidth</b>	upto 150 Hz.
<b>Scale Factor</b>	40 mV/°/sec @ 100 °/sec
<b>Non-Linearity</b>	< 0.2% of full scale
<b>Non-Symmetry</b>	< 0.2% of full scale
<b>Temp. Coefficient</b>	< 200 ppm/°C.
<b>Zero Offset</b>	0.0 +/- 0.01 °/sec (1σ) Max @ 25 °C.
<b>Bias Resolution</b>	< 0.002 °/sec
<b>Bias Stability</b>	< 0.01 °/sec
<b>Bias Repeatability</b>	< 0.03 °/sec
<b>Thermal Drift</b>	< 0.10 °/sec (over full temp. range)
<b>G sensitivity</b>	< 0.01 °/sec/g
<b>Hysteresis</b>	< 0.04 °/sec
<b>Noise</b>	< 0.01 °/sec/√Hz. (to 100 Hz. BW)
<b>Start-up Time</b>	< 0.5 sec
<b>Accelerometer (Each of 3-axis)</b>	
<b>Linear Acceleration Range</b>	+/- 500 g (max)
<b>Frequency Response</b>	upto 300 Hz. @ 10g accel range
<b>Mounted Resonant Frequency</b>	1200 Hz. @ 10g accel range
<b>Zero Acceleration Output</b>	+/- 2.0 mg (1σ)
<b>Bias Stability</b>	+/- 2.0 mg (1σ)
<b>Damping Factor</b>	0.7
<b>Accuracy</b>	0.2 % span
<b>Temperature Coefficient</b>	1.2 % span
<b>Output Noise</b>	10 μVp-p
<b>Warm-up Time</b>	< 1 min (to within 0.02 °/sec)
<b>Misalignment Angle</b>	< 2 mRad
<b>Vibration</b>	20 g's rms, 20 to 2000 Hz.
<b>Shock</b>	1000 g (0.3 msec half sine)
<b>Operating Temperature</b>	-25 to +65 °C.
<b>Full Scale Output</b>	+/- 4.0V DC

## ISIS-IMU

### Pin Description

1	rate x analog output	
2	rate y analog output	
3	rate z analog output	
4	accel x analog output	
5	accel y analog output	
6	accel z analog output	
7	gnd	
8	gnd	
9	gnd	
10	external clock input	GPS use
11	external interrupter input	GPS use
12	discrete output 2	TTL level
13	discrete output 1	TTL level
14	rs-422 txd (-)	
15	rs-422 rxd (-)	
16	rs-422 txd (+)	
17	rs-422 rxd (+)	
18	gnd	
19	+5v power input	4.75 v – 5.25v , 0.5 amp max
20	+5v power input	
21	power gnd	
22	power gnd	
23	-5v power input	
24	-5v power input	
25	gnd	
26	memory control input	factory use only

Inertial Science, Inc.

3533 Old Conejo Rd. Suite 104, Newbury Park, CA 91320, USA

(805) 499-3191 or FAX (805) 498-4882

<http://www.inertialscience.com>

Specifications are subject to change without notice.  
Copyright© 1999, Inertial Science, Inc. All Rights Reserved. ISIS-IMU