

cAVR test board 2006/06/12

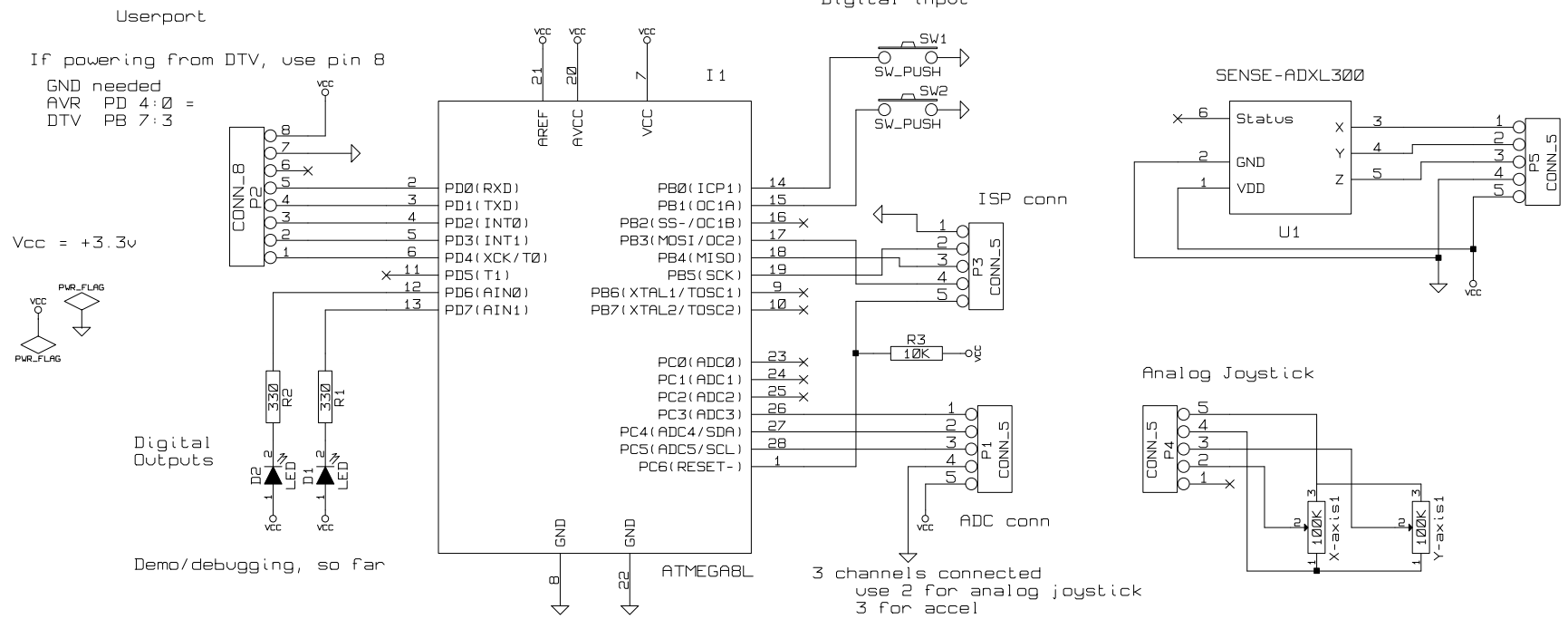

(c) 2006 By Doug Garmon
 Released under the Gnu Public Licence

Title: cAVR64	Date: 14 jun 2006	Rev: alpha
Size: A4	KiCad E.D.A. EESchema (2006-03-28)	Sheet: 1/1