

# THE CALLBOARD

OF THE REDWOOD EMPIRE DIVISION



Visit RED at Website: <http://home.earthlink.net/~campgus/>

July – September 2005

## July Meeting

### Summer Picnic at the Lake County Model Railroad Club

The Sunday, July 17 Redwood Empire Division (RED) picnic and meet will be held at the Lake County Model Railroad Club in Lakeport. The club is in the former National Guard building at the Lake County Fairgrounds located at 401 Martin Street. The picnic will begin after 12 o'clock.

The picnic area is about 100 yards from the club building. Please bring your favorite picnic lunch; hot coals will be provided if you want to barbecue. Sodas and bottled water will be supplied by RED. Also bring some folding chairs and a folding table, if possible, because existing tables are limited. As an alternate, bring a blanket to set on the grass.

The club layout is under construction but a portion of the mainline is operational and is set up to run DC or (Digitrax) DCC. You can bring your equipment (& Digitrax throttles) and try out the mainline. The total building is 30 by 50 feet with about one-half covered in layout.

The building is handicapped accessible with a wheel chair ramp and wide aisles.

Two clinics will be presented by club members Dave Frommer and Mike Ernst. Dave's topic is "Art of Model Railroading (with apologies to Frank Ellison), Your Models on Canvas" which is about digital photography for your models. Dave asks that you bring your digital camera; he will have a printer and computer to show what can be done. The second program by Mike Ernst is on casting in plaster. Mike has cast several buildings, rocks and retaining walls for the club layout and will demonstrate his technique.

When you arrive in Lakeport on Highway 29, exit at the Lakeport Blvd. exit and turn toward the lake (east). Go to the three-way stop and turn left (north) onto Main Street. Go to D Street and turn left. Go through the gate into the fairgrounds. The

club building is the first building on the left. It is two stories with the second floor accessible on-grade up the hill. The picnic area is past the building to the right. You can see the grassy area on the right through the stock barns.

Using Highway 175 from Hopland to Lakeport in **NOT** recommended unless you are prepared for a very curvy road. From the north (Ukiah and north) the best approach is Highway 20 from 101. Just before Upper Lake there is a junction with Highway 29 that brings you to Lakeport. From the south, go to Calistoga and follow Highway 29 through Middletown to Lakeport. The St. Helena hill between Calistoga and Middletown is curvy too, but not like Hwy. 175 – which is best left for those in sports cars who like curves with no guardrails.

Please plan to arrive by 1 PM.

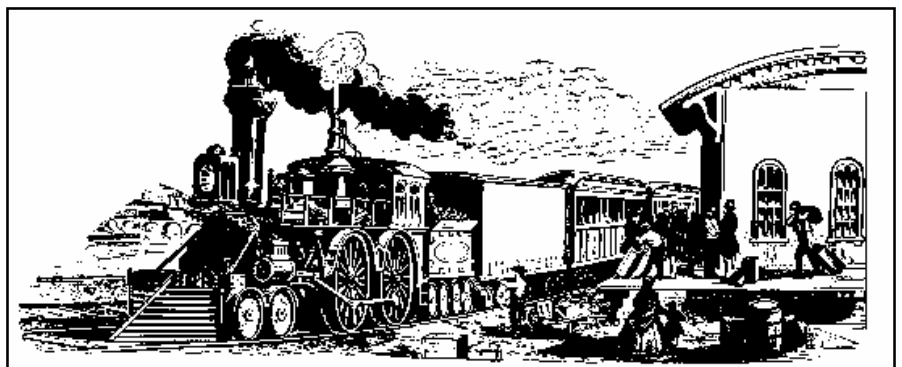

## STAFF ROSTER

### DIRECTOR

Ron Plies  
P.O. Box 950, Fortuna, CA 95540  
(707)725-5411  
E-mail: [rlplies@cox.net](mailto:rlplies@cox.net)

### SUPERINTENDENT

Nolan Alexander  
95 Maria Drive, Petaluma, CA 94954  
(707)778-7656  
E-mail: [nolanalexander@msn.com](mailto:nolanalexander@msn.com)

### CHIEF CLERK

Steve Skold  
5306 Yerba Buena Rd, Santa Rosa, CA 95409  
(707)539-1782  
E-mail: [sandcskold@aol.com](mailto:sandcskold@aol.com)

### CONTESTS

Steve Skold  
5306 Yerba Buena Rd, Santa Rosa, CA 95409  
(707)539-1782  
E-mail: [sandcskold@aol.com](mailto:sandcskold@aol.com)

### MEMBERSHIP

Gus Campagna  
PO Box 6344, Santa Rosa, CA 95406-0344  
E-mail: [campgus@earthlink.com](mailto:campgus@earthlink.com)

### TRAIN SHOWS

John Leins  
731 San Marco, Fairfield, CA 94533  
(707) 422-8266

### LAYOUT TOURS (vacant)

### NOMINATIONS

Ed Zakareckis  
2408 Homestead Court  
Fairfield, CA 94533-7137  
(707)425-1159  
E-mail: [ezak@castles.com](mailto:ezak@castles.com)

### ACHIEVEMENT PROGRAM

Harold Mentzer  
102 Berna Avenue, Napa, CA 94559  
(707) 226-5153  
E-mail: [hsmmentzer@aol.com](mailto:hsmmentzer@aol.com)

### ESTATE COUNSELOR

Don Clauder  
305 Garfield Park, Santa Rosa CA, 95409  
(707) 539-3510

### CALLBOARD EDITOR

John Rolston  
240 Chase St., Sonoma CA, 95476  
(707) 938-5478  
E-mail: [jrolston@pacbell.net](mailto:jrolston@pacbell.net)

## DIRECTOR'S REPORT BY RON PLIES

Well, it's official now. We have a single pay dues with the NMRA at \$45.00 and a \$6.00 subscription fee for the PCR *Branch Line* newsletter. In the past, the dues for the NMRA were \$45.00 and the dues for the PCR/RED were \$6.00.

So what is different? Now the dues will all come on one bill. You will automatically join the PCR/RED **but** the subscription for the *Branch Line* is optional. Only a yearly newsletter will be sent to those who do not subscribe. If you wish to stay up to date, you'll need to pay the \$6.00 fee. The board had a split vote of 3 to 2 to implement this plan. This director and one other director did not approve of the split fee.

When the NMRA membership voted for a single pay program, I thought it would be a one dues payment to one organization - with no sub class of membership. All NMRA members living in the boundaries of the PCR will now be members of the PCR and RED. I believe we have an obligation to keep our members informed and hopefully get them involved. The number of people coming to the conventions and regional meetings has been declining but if we can get the word out to all our members, new and old, we hope to see this trend reversed.

The NMRA will now send a \$2.00 per member rebate, from the \$45.00 dues, to all regions. The PCR did not receive this previously. This director, and your publications manager GUS CAMPAGNA, recommend that no fee be charged but instead use the interest income from the PCR savings accounts. This, along with possible advertisements, would pay the cost.

The two arguments against this proposal were that we would find it hard to impose a newsletter fee later, if it

was needed, and the interest should continue to accrue.

I'm thinking about suggesting to the Board, as an alternative to the current plan, that a newsletter be published 4 times a year for whatever the \$2.00 NMRA rebate will buy. The argument against this is that we need to use this rebate for unspecified administrative costs - which have not posed a problem in the past.

To summarize: the PCR Board feels that without a *Branch Line* \$6.00 fee they can not afford to publish it and the board feels they do not wish to use the savings account interest or principal. I suggest that we live within our means and send out a newsletter 4 times a year for whatever the \$2.00 per member per year will buy. This way all members can be informed as to the activities of the PCR and we can get maximum participation from the membership. If we want to publish the *Branch Line* in its present format with the same kind of quality, we can post it on the PCR web page, as we are presently doing, and let members and others download it for their use. This way there is no additional cost and there will be no need to keep an updated list of members. The San Luis Obispo model railroad club used this method very successfully.

Please let me know how you feel about this subject. My contact information is listed to the left. Thank you for your responses.

At this year's PCR convention, I had the pleasure of announcing that BILL KAUFMAN was selected for the RED member of the year award. Bill has done an outstanding job as the PCR *Branch Line* editor and has kept the newsletter quality at a high level. Be-

(Continued on page 3)

(Director's Report Continued from page 2)

cause of the PCR board's decision regarding a subscription fee, Bill has resigned as *Branch Line* editor (after the next issue) and so the type and quality of future *Branch Line* newsletters is unknown.



Photo by Steve Skold

BILL KAUFMAN with his award.

### From the SUPERINTENDENT BY NOLAN ALEXANDER

Well that's it; as of last night (6/21) summer is officially here. It's time to get out there and do all that summer model railroading activity including the RED annual picnic. This summer we're going up to Lakeport and I hope you're looking forward to it as much as I can. There is a good program planned and we always have fun at the picnic. I look forward to seeing you there.

Starting in September, RED will have a significant increase in its membership. With the adoption of the new NMRA bylaws and organizational structure, anyone who lives within the geographic boundaries of

the Redwood Empire Division will be a member. We're planning ways to reach all of those new members and the best way to do this is still the newsletter you're reading right now. The next two *Callboard* issues will be mailed to everyone, but we won't be able to continue to absorb the increased cost for too long.

One of the ways we can cut the cost is to deliver the *Callboard* via the web. We can send you an e-mail when the issue is on the web site with a link to take you right to the site; to do that we need to know if you have an e-mail address. So, if you'd drop us a line or give a call with your e-mail address, we'll start getting it set up. If we don't hear from you, then you should expect to hear from one of us soon.

I'm still looking for people to step forward and say that they'll help put on a model railroad show in the Santa Rosa area. A handful of folks have committed to help so far but I'm going to need about fifteen more. Again, if I don't hear from you, expect a call. RED is going to need operating funds and this seems to be the best way to get them. Besides, we'll have a lot of fun!

Have a great summer of railroading fun and I'll see you at the picnic.

### ANNUAL MEETING OF THE REDWOOD EMPIRE DIVISION

Date: May 1, 2005

CALL TO ORDER TIME: 1:14 PM

1. APPROVE MINUTES OF LAST MEETING (as published in the 4-6/2005 CALLBOARD). Moved, seconded and passed unanimously.

2. TREASURER'S REPORT by Chief Clerk STEVE SKOLD

Total 2004 income: \$401.50  
Total 2004 Expenses: \$731.34  
Current cash balance: \$2974.68

3. OTHER COMMITTEE REPORTS  
Ballot Report by ED ZAKARECKIS.

4. OLD BUSINESS None

5. NEW BUSINESS

A. RED will no longer coordinate model train exhibits at the annual Apple Blossom Festival in Sebastopol due to poor public attendance.

B. There was a lengthy discussion about RED holding a public train show during 2006 to generate more operating funds.

ADJOURNMENT TIME: 1:45 PM

### MEMBERSHIP REPORT BY GUS CAMPAGNA

Welcome to our newest member MICHAEL TOBENER of Cloverdale.

As membership chair I'd like to remind all members of a very special benefit of being a NMRA member – which is the Kalmbach Memorial Library (KLM). The library is a great resource for your modeling needs. Information can be found on-line at [www.nmra.org/library/](http://www.nmra.org/library/) They have books for sale, tapes for rent, and can look up and copy articles in magazines that are out of print.

Missing an instruction sheet to a kit that has been on your shelf so long that you forgot where you bought it? Well the KLM probably has the kit instructions on file and will send you a photocopy. Researching a prototype and run into a dead end? Contact KLM and they will check their resources and most likely return positive results in just a few weeks turnaround time.

Another benefit of membership is the NMRA on-line modeling information e-mail list. There are two lists; the NMRA General List and the NMRA Modeling list. Both lists are very informative. Questions asked on the Modeling List are usually answered quickly. There currently is

(Continued on page 4)

(Membership Report Continued from page 3)

quite a lively discussion on the General List of NMRA/SIG relations, the KLM and rail photography. To join the lists, send an email to [general-owner@lists.nmra.org](mailto:general-owner@lists.nmra.org) with Subscribe in the subject line. Include your name, address and NMRA number in the body of your message.

Conventions are another benefit of membership. We just completed another great PCR convention and the NMRA national in Cincinnati will be history by the second week of July. If you didn't get to these events you missed a lot of fun times with friends and great inspiration to move ahead on your own model railroading adventures. Information about next year's PCR convention is on-line at <http://home.earthlink.net/~rivercityexpress/index.htm>

See you in Lake County.



## CHIEF CLERK'S REPORT BY STEVE SKOLD

Election results were announced for the two year terms for Superintendent and Chief Clerk/Paymaster. Nolan Alexander and Steve Skold were re-elected. Thank you to all who voted. We have had several discussions about how the new NMRA single dues structure and reorganization will effect the Redwood Empire Division. We generally operate at a loss during the years except when we get an infusion of capitol from hosting a PCR Convention. The last convention broke even so we will have to find an additional source of funds to continue our *Callboard*. We are

discussing going to an electronic version of the Callboard that will do away with costs of printing and mailing. If you have an ideas in this regard, please pass them on to Nolan or myself. If you do not have a computer or are not online, write us and let us know. As of September, we will be adding all the NMRA members that have not been previously joined PCR and this will place additional pressure on operating funds.

Details for the RED summer picnic are on page 1. I hope many of you make the effort to attend. The clinics sound great and we will have coals for BBQ and will provide soft drinks and ice.

Our November meet will be held in Tiburon. BILL KAUFMAN will be presenting his clinic on the State Belt Railroad of San Francisco. He has some great photos of the old waterfront. If anyone has any information on this operation or old pictures, I am sure he would love to hear from you. Also congratulations are in order for Bill as he is this years recipient of the RED Member of the Year Award.

## CONTEST/DISPLAY REPORT

BY STEVE SKOLD

RED came out with a big percentage of the awards at the recent PCR Contest at the Concord Convention.

JOSEPH AYMAR won Best In Show for his SP Diesel. He also took 1st place honors in Structure Open and Maintenance of Way Open. RON PLIES won 1st in Passenger Open. In the photo contest, BILL KAUFMAN was 2nd and 3rd in Model Color Print, 2nd in Trains in Action and 1st and 2nd in Other Prototype Print. STEVE SKOLD was 3rd in Trains in Action.

CAROL SKOLD was 2nd in General Pattern with her quilt.

Now is the time to get started building a model for the PCR Convention next year in Sacramento. There will be no contest at the summer meet in Lakeport. I still need someone to take over as Contest Chairman for RED. Let me hear from you.



Photograph by John Rolston

Newly re-elected RED officers Steve Skold and Nolan Alexander

# THINK SMALL

## Signals II

Little red and green lights beside your tracks can be a pleasing addition to your modules or layout. The effort required to attain smiles is small when compared to other embellishments we might add. The signals at Bodega's station corrected my forgetting of the crossing selector switch ( the lever controlling power to the crossing ). Then February's Scale Rails pushed me into buying a commercial version of the featured signal circuit. One of my simple signals (common anode, red and green ) connected to the "occupied" and 'clear' terminals of a BD-2 (Circuitron's Current Sensing Detection Unit) now protects the first part of my mostly hidden main line. The protected section extends from tunnel portal T-5 to the turnout for the loggers sneak. My signal turns from green to red whenever a train is in that block.

I smiled. The signals at the station looked neat. The signal at the tunnel portal faithfully monitored the approach or departure of trains from sight.

BUT ! There were clouds on the horizon.

Sean, who is throttle qualified on my layout, came to visit. I flip the block switches and attend to turnouts when required but Sean runs the trains. Six year old Sean obeyed the departure signal at Bodega. The signal at T5 drew more attention. Kids do not learn about block occupancy at school.

After running a few trains, he sand-bagged me with a logical question –the wisdom of kids - 'If signals are needed when trains leave Bodega, why are there no signals for trains coming back?' The kid was totally correct. I had provided protection on the south side of the crossing but the north side had nothing. By focusing on my 1:1 problem of forgetfulness the 1:87 world lost its creditability.

With our model railroads we struggle to attain a small version of the real thing. Our steam engines have cold fireboxes and our diesel locomotives are non-polluting as tiny electric motors make

them go. However, they look like the big machines that make our eyes glow and hearts thump. We have fun with miniature replicas - not toys.

The wisdom of a little boy made me think. Yes -Houston, I had a problem indeed !

The rails just north of Bodega's station are a bit more complex than the simple crossing of two main lines diagrammed last time for 'Signals I'. Here is the big picture.

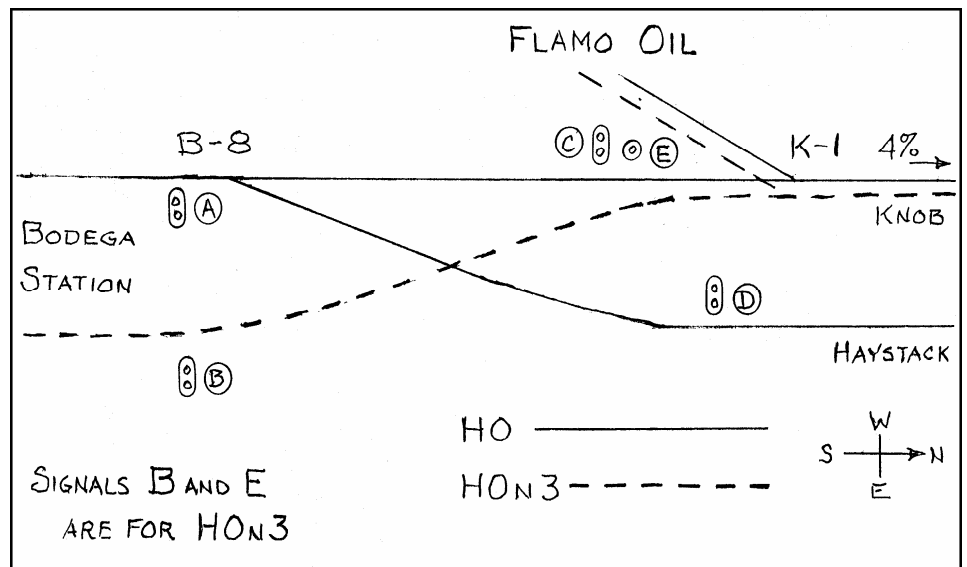

The narrow gauge main line is actually dual gauge because wide gauge log and ore trains share the right of way up Knob Hill and use turnout B-8 when going to and from Bodega Yard. Also, Flamo Oil has important traffic for both gauges via turnout K-1 just before the rails start the 4% climb into the hills. Spend a few minutes looking over the track diagram. Signaling the complex would require a bit of thinking. Sean had shown me one dumb move. I did not want another.

Railroads spend money for signals to solve problems and improve safety. We modelers often place signals for cosmetic effect. However, the eye catching little critters often make operations more enjoyable. Our best choice is to have signals that look right the railroad AND enhance our fun while running trains. It was time for some serious planning.

The need for south-bound signals at Bodega made me smile. I had the excuse for a fun project on the workbench. The head

scratching to make it work could come later. The little red and green lights beside the tracks dress up the layout. More important, they are easy and fun to build.

My first step was to collect the dried up ball point pens from various drawers - my additional signals would need brass tubes for masts. OUCH! - another part of my world where Big Oil flexed its muscle. The ink supply for ball point pens is now stored in plastic tubes made

from oil. Result-- Plan B - K&S supplies brass and copper tube in assorted diameters to local and mail order hobby suppliers. Plus 3/32" (about 8" HO) would be a more dainty diameter than the 11" provided by my obsolete pen tubes. Stock No.1268 provides three 12" lengths of 3/32" brass tube. Bowing to life's changes I dug into my scrap boxes. My supply of bits of sheet styrene is strong. Building the 2'x4'x5' relay boxes to support the masts would be no problem. BUT, I could find no ladder stock. Our hobby has matured. We do not slap the stuff on boxcars with printed cardboard sides. Ladder stock by the foot or yard has joined rotary dial telephones and 5 cent root beers. What to do? The ladder's metallic path for electrons is vital for my simple signals. I took the well worn path trod by short line railroads and old-model rails: "When you can't buy it you make it".

(Continued on page 6)

(THINK SMALL Continued from page 5)

Find a small chunk of hardboard or smooth plywood, three short lengths of HO scale 2x10 basswood and some straight brass or copper wire about 0.023 inches in diameter. If your hobby supply can't help you, bare 22 gauge brass or copper wire (0.025" Dia.) will be stiff and straight if you clamp one end in a sturdy vise and pull hard on the other end until the wire "yields". Tin the wire and you have the material for the side rails and steps. The next step is a tweezer and small soldering iron project. With a simple "jig" for assistance your ladder factory will surprise you. If you cut the steps a tad long and trim to length after they are soldered in place the job will be less stressful. The ladder jig is quite simple.

After soldering the steps in place, a few swipes with sandpaper and or small files will remove the bumps from your hand crafted metallic ladder. Remember, we are building SIMPLE signals not contest entries. Flat black paint will divert attention from any minor defects when eyes are focused on those red and green lights. An alternate approach is to photoetch some ladder stock. I am not that brave. Etching uses nasty chemical stuff that smells bad and pushes my worry button.

Wow! You were working for the supply

department; but now we can get on with providing proper signaling at Bodega station. I beg your pardon for not knowing I was specifying obsolete materials.

Signals A and B remain in place but they

stack or B-8 is set for Knob and K-1 is set for the main line. Any time the crossing is set for narrow gauge, signal A must be red. If broad gauge has the crossing and B-8 is set for Knob, the

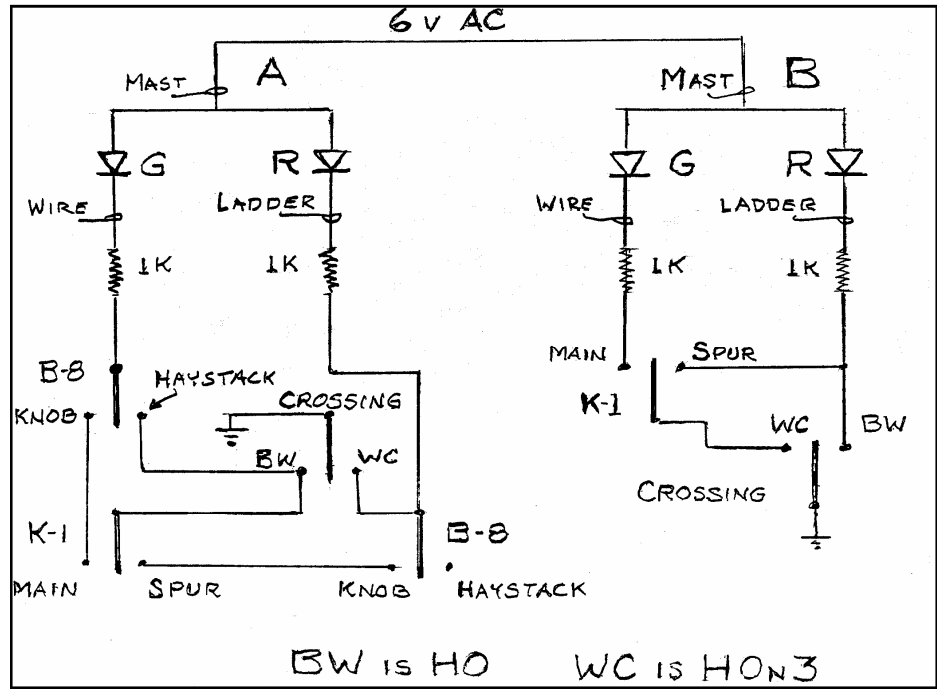

needed new wiring to look at conditions at turnouts B-8 and K-1. Contacts in addition to those available could be via micro switches on the turnout throw bars or via relays. Signal A should show green when Bodega Western has the crossing and B-8 is thrown to Hay-

signal must still show RED if K-1 is thrown toward the Oil spur. This requires DPDT contacts on turnout B-8 and SPDT contacts for turnout K-1 and the crossing control.

Signal B's wiring also became a bit more complex. The green light requires both the crossing and K-1 set for the main line. SPDT contacts for the crossing and K-1 do the job. Signal A's lashup is the seriously complex one. Thinking through the contacts for proper Red and Green was a challenge. Remember the rule: Green - series all clear. Red - any hazard.

My simple common-anode signals are now meeting all north-bound requirements for both 1:1 and 1:87. This is a good place to pause.

The south-bound signals plus diode duplexing with single unit red-green LED's are stuff for next time.

As Felix Katz said "Knowing the right connections is important" -for signals, that is.

Bill Williams The Ancient One

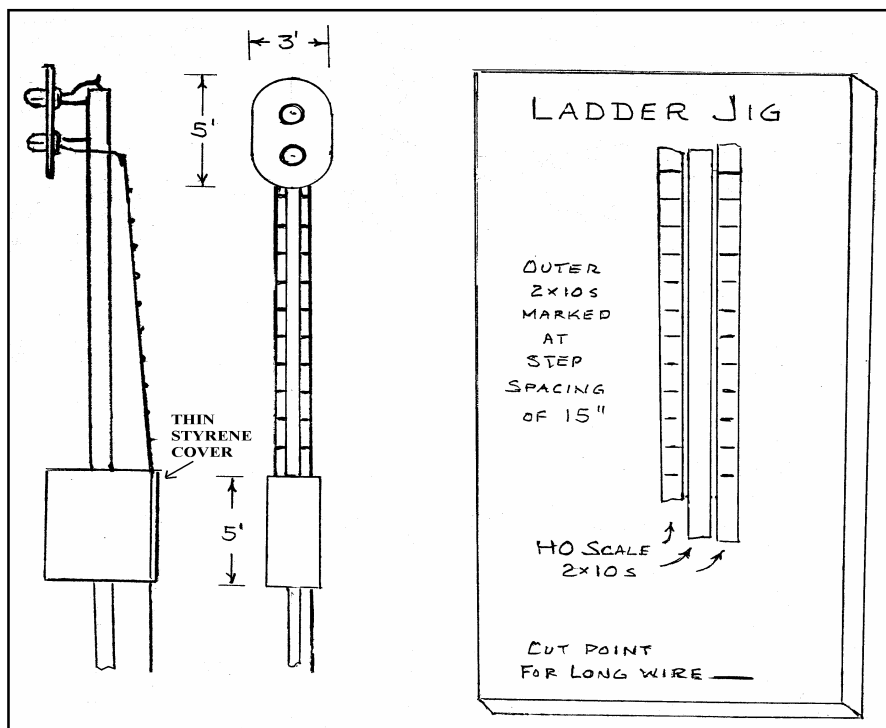

**Redwood Empire Garden Railway Society (REGRS)**, No. 1 gauge, various scales. If you are interested call Ken Brody at (707)526-0195 or e-mail [wstie@sonic.net](mailto:wstie@sonic.net)

**Napa Valley Model Railroad Historical Society**, HO layout. Meets Fridays 7:30 PM at Napa Fairgrounds, 575 Third St., Napa. For information call: Clubhouse (707)253-8428 or Ron Rogers (707)224-4040 or John Rodgers (707)226-2985. [www.nvmrc.org](http://www.nvmrc.org)

**Lake County Model Railroad Club**, HO layout. Meets Wednesday at 7:00PM in the old National Guard Building at the Lake County Fairgrounds on Martin Street, Lakeport. Call Mike Ernst at (707)263-4949

**Coastal Valley Lines**, HO modular. Meets 1st Thursday of the month at 7:00 PM at Sam's For Play Café, 2630 Cleveland Ave., Santa Rosa. Call Brad Squires (707) 568-4298 or Don Hanesworth 823-9615  
<http://home.pacbell.net/jrolston/>

**Solano Rail Rats**, HO Scale. For information call John Leins (707)422-8266

**O Scale Modular Group** is forming in Santa Rosa. Contact Don Clauder at (707)539-3510

**CLUB SCHEDULES**

**Carquinez Model Railroad Society** is the new name for the **Vallejo Model Railroad Club**, which is presently moving to Crockett, CA. New contact information, including a new website address, will be established soon.

**Sonoma County Model Railroad Society (SCMRS)** is looking for members to help create a large permanent HO scale model railroad display located in the Historic Healdsburg Railway Depot building. Discussions regarding usage of the building are underway with various governmental entities. Contact Dave Gibbons at (707)526-2057 or [rrgibbons@sonic.net](mailto:rrgibbons@sonic.net)

**Humboldt Bay & Eureka**, HO layout, Eureka, CA. Contact David Berriman, P. O. Box 915 Arcata, CA 95518. (707)825-7689.

**NPC Operators**. An On3 operating group meets one Sunday each month. Contact Steve Skold (707)539-1782 or e-mail [SandCSkold@aol.com](mailto:SandCSkold@aol.com)

**Bay Area S Scalers**. Contact Lee Johnson at (925)943-1590.

**Mendocino Coast Model Railroad &**

**Historical Society**, a Fort Bragg area group that promotes the hobby of model railroading. This group meets the 3rd Saturday of each month. At present, HO modules are being constructed. Contact Phil Miller at (707)937-3605 for more information.

**Redwood Empire Live Steamers**. A new group is forming with the goal to build a 7 1/2 inch track facility in a local park. For information, call Don or Ann Bruner Welch at (707)578-4414 or write to PO Box 4594, Santa Rosa, CA 95402  
[www.santarosals.org](http://www.santarosals.org)

**North Coast Live Steamers**, a group, from the Fort Bragg-Willits area, that promotes the hobby of large-scale railroading and other steam related history. Contact Bill Shepard at (707)961-0329.

**Eel River Valley Model Railroaders**, HO Scale layout. Meets each Friday evening at 7:30 P.M. at the Humboldt Co. Fair Grounds, Ferndale, CA. Write to P O Box 950 Fortuna CA 95540 or contact Ron Plies at (707)725-9063 or [rplies@cox.net](mailto:rplies@cox.net) for more information.  
[www.eelrivervalleyrr.org](http://www.eelrivervalleyrr.org)



**MEMBERSHIP APPLICATION** 4/05  
 REDWOOD EMPIRE DIVISION (RED)  
 PACIFIC COAST REGION (PCR)  
 NATIONAL MODEL RAILROAD ASSOCIATION (NMRA)

LAST NAME: \_\_\_\_\_ FIRST NAME: \_\_\_\_\_

ADDRESS: \_\_\_\_\_

CITY: \_\_\_\_\_ STATE: \_\_\_\_\_ ZIP: \_\_\_\_\_

TELEPHONE #: \_\_\_\_\_ NMRA # (if a member): \_\_\_\_\_

I want to become a member of the Redwood Empire Division in the Pacific Coast Region of the NMRA. I have checked below the type of membership I desire and have enclosed the proper amount in a check payable to PCR-NMRA. I understand that membership in the RED/PCR requires membership in the NMRA.

- |  |   |
|--|---|
| <input type="checkbox"/> RED/PCR and NMRA for one year at \$51.00  | <input type="checkbox"/> RED/PCR only (requires NMRA membership # above) at \$6.00  |
| <input type="checkbox"/> RED/PCR and NMRA for five years at \$240.00   | <input type="checkbox"/> RED/PCR only five years (requires NMRA # above) at \$25.00 |
| <input type="checkbox"/> RED/PCR and NMRA affiliate at \$29.00<br>(No NMRA monthly <i>Scale Rails &amp; Bulletin</i> magazine) | <input type="checkbox"/> Check here if this is a renewal PCR #: _____               |
| <input type="checkbox"/> RED/PCR and NMRA Youth (under age 20 ) at \$36.00<br>Date of Birth: _____                             |   |

Life memberships in both the NMRA and RED/ PCR are available. Contact Member Services Chairman for actuarial quote. Send application form and remittance to : PCR Member Services, 530 Fig Tree Lane, Martinez, CA 94553. Please allow 3-6 weeks for processing your application.

**COMING DOWN THE LINE**

- July 3-9: **NMRA National Convention**, Cincinnati, OH.
- July 17: **Redwood Empire Division** meet in Lakeport. Details are on page 1.
- July 21: **NWP Whistlestop** program, San Rafael.
- July 31: **Redwood Empire Garden Railway Society** meet at Bob Guy's home #
- August 11-21: **Eel River Valley Model Railroaders** open house during the Humboldt Co. Fair at Ferndale California.
- August 20: **Napa Valley Model Railroad Historical Society** annual swap meet & show, 8-2 #
- August 26-28: **Portola Railroad Days**, Western Pacific Museum at Portola
- August 28: **Redwood Empire Garden Railway Society** meet at Martin Cahill's home #
- September 11: **Roots of Motive Power** annual picnic, Willits
- September 11: **Coast Division** meet at Buchser Middle School in Santa Clara.
- September 24 &25: **Coastal Valley Lines** train show at Oakmont in Santa Rosa #
- September 25: **Redwood Empire Garden Railway Society** meet at Hart Corbett's home, Novato. #
- November 20: **Redwood Empire Division** meet in Tiburon, Marin County.

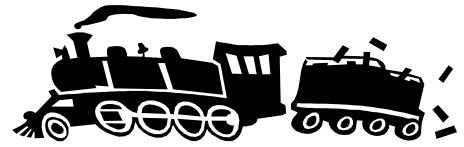

**EDITOR'S NOTES:**

Future CALLBOARD schedules are as follows:

- October- December CALLBOARD Staff Meeting:** 7:30 PM, October 18
- Text Deadline:** October 25
- Mailing:** November 1
- Meeting:** November 20

Submit all articles, calendar items, adds and comments to the Editor.

**Send address corrections to:**  
**PCR, 530 Fig Tree Lane**  
**Martinez, CA 94553**

# Contact information is listed on page 5.

Visit RED at Website: <http://home.earthlink.net/~campgus/>

**CALLBOARD**  
 John Rolston, Editor  
 240 Chase Street  
 Sonoma, CA 95476

FIRST CLASS