

# THE CALLBOARD

OF THE REDWOOD EMPIRE DIVISION



Visit RED at Website: <http://home.earthlink.net/~campgus/>

January – March 2004

**All Railroad enthusiasts are welcome to enjoy an afternoon of model railroading fun on Sunday, February 8th.**

*There is no charge to attend.*

## February Meeting

at the

Napa Valley Northern RR  
Napa

The first 2004 meeting of the Redwood Empire Division will be held in Napa on Sunday February 8 starting at 1 PM. The hosts for this meet will be the Napa Valley Model Railroad Historical Society, operators of the Napa Valley Northern Railroad. They are located in Napa on the grounds of the Town & Country Fairgrounds at the Third Street gate.

Doors open at noon so come and enjoy SHIRLY MENTZER's great sandwiches, brownies, cookies and coffee. The club sells cold sodas as well.

The Napa Club invites you to bring your pet locomotives and rolling stock. The only requirement is that the equipment meets NMRA standards and has properly aligned Kadee couplers. The decision on any questions will be at the discretion of the Napa Club.

As usual, everyone will get a free door prize ticket. If you are wearing your Division name badge, it will be worth an additional free ticket, as will bringing a model for the contest display (see **Contest Report** on page 3) and/or at least one guest.

Tickets can be purchased (3 for each dollar) for the special door prize, which will be a \$25.00 gift certificate donated by **The Loose Caboose Hobbies** store in Napa. They are located at 2233 Brown St., just north of

Lincoln Ave. across from the Napa High School. The phone number is (707)258-1222. They will be open on Sunday from Noon to 5 PM, so drop by and say hello to RAY DAHLGREN and his crew and thank them for the day's special door prize.

A short RED business meeting will be held to accept nominations for RED Director and for a report on the state of our division.

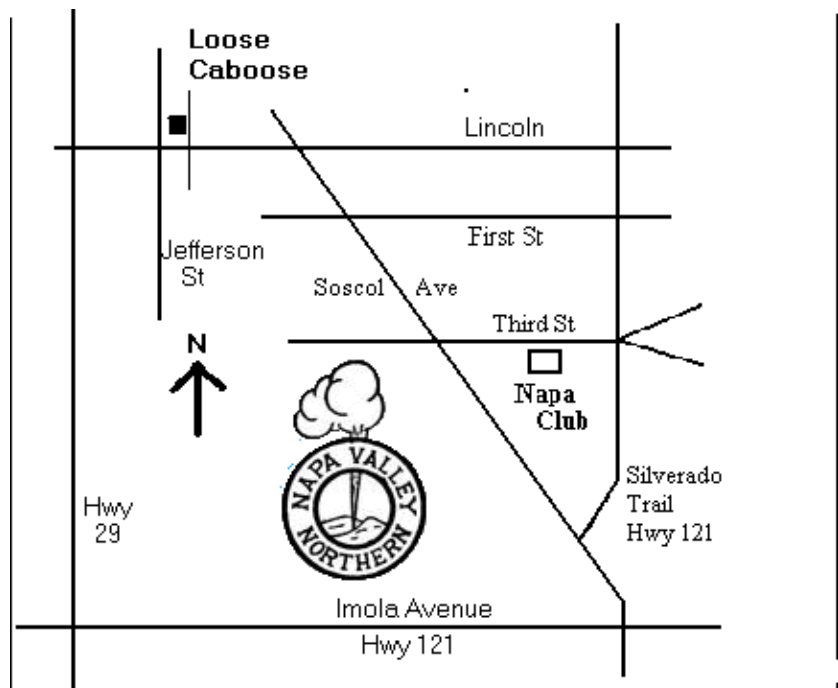

## STAFF ROSTER

### DIRECTOR

Ron Plies  
P.O. Box 950, Fortuna, CA 95540  
(707)725-9063  
E-mail: [rlplies@cox.net](mailto:rlplies@cox.net)

### SUPERINTENDENT

Nolan Alexander  
95 Marin Drive, Petaluma, CA 94954  
(707)778-7656  
E-mail: [nolanalexander@msn.com](mailto:nolanalexander@msn.com)

### CHIEF CLERK

Steve Skold  
5306 Yerba Buena Rd, Santa Rosa, CA 95409  
(707)539-1782  
E-mail: [sandcskold@aol.com](mailto:sandcskold@aol.com)

### CONTESTS

Steve Skold  
5306 Yerba Buena Rd, Santa Rosa, CA 95409  
(707)539-1782  
E-mail: [sandcskold@aol.com](mailto:sandcskold@aol.com)

### MEMBERSHIP

Gus Campagna  
PO Box 74, Kentfield, CA 94914  
E-mail: [campgus@earthlink.com](mailto:campgus@earthlink.com)

### TRAIN SHOWS

John Leins  
731 San Marco, Fairfield, CA 94533  
(707) 422-8266

### LAYOUT TOURS

Pat Boyle  
6425 Vine Hill Rd, Sebastopol, CA 95472  
(707) 576-7605  
E-mail: [patnt@sonic.net](mailto:patnt@sonic.net)

### NOMINATIONS

Ed Zakareckis  
2408 Homestead Court  
Fairfield, CA 94533-7137  
(707)425-1159  
E-mail: [ezak@castles.com](mailto:ezak@castles.com)

### ACHIEVEMENT PROGRAM

Harold Mentzer  
102 Berna Avenue, Napa, CA 94559  
(707) 226-5153  
E-mail: [hsmmentzer@aol.com](mailto:hsmmentzer@aol.com)

### ESTATE COUNSELOR

Don Clauder  
305 Garfield Park, Santa Rosa CA, 95409  
(707) 539-3510

### CALLBOARD EDITOR

John Rolston  
240 Chase St., Sonoma CA, 95476  
(707) 938-5478  
E-mail: [jrolston@pacbell.net](mailto:jrolston@pacbell.net)

## DIRECTOR'S REPORT BY RON PLIES

Our topic has been, for the last few times, the subject of contests. I would like to give one more view from Duane Buck, who has done outstanding work at the national level and has been a contest judge. Duane has been a model railroader for over 54 years and was the winner of the National Model contest Gold Award in Toronto last July. You can view his work if you will look in the *Scale Rails* December 2003 issue on page 35. Duane's view is:

*Contests are one of the main attractions at all NMRA meets and conventions. Every attendee cycles through the contest room during these events. While viewer interest is always high, the number of persons actually entering models in the contests is dwindling.*

*Why are we having fewer model contest entries? When we ask our fellow NMRA members why they don't enter the contest, the replies are pretty much standard. They "don't like to fill out the paperwork" is the most used excuse. "I'm not a competitor." "It takes too long to build a contest quality model". "I don't have the time." "I don't have the skills to compete." We hear these excuses over and over again. Some are unsure of their modeling skills and fear embarrassment. Most of the contestants we see on the division and region levels are the repeaters, while the contestants on the national level change with geographic locale.*

*How can we get more people to participate in the model contests? A complex question. There are a number of things that can be done to increase participation. First, is the ready availability of the contest chair to the members. This can be done through informative columns in division and region publications along with personal attention to members' needs in the contest room and by answering questions received (by e-mail or any other means) in a timely fashion. Second, encouraging members to participate. Again, this can be done through division and regional publications. Perhaps more important is personal contact-by complimenting individuals after viewing their work and showing interest in their modeling efforts. After these comments, let me*

*say that I believe the contest and judging format must be changed. I will explain below. We've initiated the PSR President's Award for those who enter a regional contest for the first time. The President selects the recipient. It is a added incentive.*

*Should we allow observers in the contest room during judging periods? I have mixed emotions with regard to this issue. However, I do tend toward the affirmative. Observers must understand that they have to stand back and allow the judges to do their work and most of all, remain silent. There are times when space consideration might dictate no access to observers.*

*Contest philosophy: I believe the contest experience is one of education. Participants, judges and event attendees can all learn from the process. We learn from having our work fairly and constructively critiqued. We learn through viewing the work and techniques of others. We learn through discussions about the models with those who visit the contest room. Another thing that should be emphasized is that the main focus be placed on the model and not the contestants ability to write an essay. Certainly an individual should be able to describe what he/she did and what the intended result was to be. It is critical to provide drawings and photos to maximize conformity score. This should be done with "free-lance" models also, to show a sample of prototype practice. Encourage persons to become judges. Place the inexperienced person with those who are knowledgeable. Oftentimes, a judge will become a contestant because of the experience.*

*Prepare early for regional contests. Two years ago I revised the PSR Contest directory and included two check lists. One for the preparation, and one for contest room procedures. This assists the local hosting contest chair in preparing for and setting up a smoothly functioning contest room.*

*As I mentioned above, I would like to see a change by the NMRA national hierarchy, to change the contest and judging format for the AP. We use a two tier model contest format in the*

(DIRECTOR'S REPORT Cont'd from page 2)

*PSR. One for open and one for kit/kitbash (less than 50% scratchbuilt) models. Unfortunately, we use the same Judge's Score Sheet for both contests. The kit-basher can be penalized 15 pts. in the scratchbuilt category, while still being expected to get the 87 1/2 pts. for a merit award. The merit award score should remain at 87 1/2 pts. in all cases. However, introducing a new Judge's Score Sheet for the kitbasher category would seem to be in order. Ten points could be transferred from the scratchbuilt category to the detail category. The Judge's Score Sheet for the open contest would remain the same.*

*Several other AP forms would have to be changed if this were to be adopted. The rationale for such a change besides fairness is as follows: It would encourage many modelers, who feel they cannot compete in a contest without a complex scratchbuilt, to participate. Another rationale is the changing complexion of our hobby. In the past two decades, the model railroad hobby has undergone a revolution, not just an evolution. This has been brought about by the introduction of a plethora of new products that are prototype specific, better detailed and much more accurate. Because of this, fewer people are scratchbuilding. If they are unable to find a model for their prototype, they can usually find a model that can be readily kitbashed to suit their needs. The contest procedures must change from the national open contest only concept to a format that can be embraced by the regions. This would also provide the bonus of consistent contest procedures throughout the NMRA. The regions would not have to exert the limited autonomy they possess in such matters.*

My thanks goes out to Duane, Keith Brownfield and Vern Alexander who took the time to write me and share their views of contests. Next time I'll share with you what I've learned from other members and my own views. Until then, if you have a view you would like to share, please email, mail or telephone; all three methods are listed in the first column on page 2.

## From the SUPERINTENDENT BY NOLAN ALEXANDER

Happy New Year. The mid-winter festivals are behind us and we have a few weeks to settle in and do some model railroading before Spring comes to lure us out of the layout room. I hope you and yours had a fine celebration and have come through healthy and well rested. May is just a little more than twelve weeks away and that means the PCR Convention is almost here. HAROLD MENTZER still needs willing hands to do the work at the convention. He needs volunteers to introduce the clinics and to help man the contest room and registration desk. Do you want to meet everyone at the convention? Take on the registration desk and you'll get your wish; they all have to come by there eventually. Our next meet is at the Napa Club and you'll have the opportunity to see Harold there and tell him how you're ready to help.

Speaking of the Napa Club, be sure to come on out to the meeting and help us run some trains. Got an engine or cars you want to run? If they meet NMRA standards and are Kadee compatible, bring them along! Got a car lettered for your home pike? Bring it and your camera and get a photo of your equipment running on a "foreign" road. Be sure to take up the offer by the Napa modelers to run a train. Mainline or local, if you don't know the route someone from the club will be there to help out. So, come on down and let's play trains! Oops, that's let's simulate the rail-based, American transportation system in 1/87th scale for all you folks that are too grown up to "play" with trains.

See you there.

## CHIEF CLERK'S REPORT BY STEVE SKOLD

The biggest news for this issue is the passing of PAUL CHRISTENSEN. Paul and I were co-workers at State Farm for 30 years and I counted him as one of my very close friends. He will be missed by everyone who knew him in the hobby. Our condolences go out to Sharon and her family.

I missed the November as Carol dragged me kicking and screaming to Kauai. Gus was good enough to take over my duties. The Special Door prize winner was PAT BOYLE winning a 5 piece video set donated by STEVE SKOLD. RON PLIES won a NWPRRHS Calendar donated by the Division. Regular door prizes were:

HAROLD MENTZER	Globe Diesels
CLARK STEWART	Athearn Box Car
BRAD SQUIRES	Athearn
Reefer HENRY FUCHS	hopper cars
STEWART BENSON	N scale stuff

Displays at the meeting were included by the following members: GUS CAMPAGNA, VERNE ALEXANDER, CLARK STEWART, HAROLD MENTZER, BILL WILLIAMS, DON CLAUDER, RON PLIES and RON LEARN.

The next meeting is at the Napa Model Railroad Historical Society. It will be our Annual Meeting. It is early this year in order to get in our nominations for RED Director to the PCR before our next meeting. RON PLIES will be running again and nominations will be accepted from the floor.

## CONTEST/DISPLAY REPORT BY STEVE SKOLD

The contest for the February meet in Napa will be a preview of the PCR Convention Contest. Bring the models you will show at the convention. We will have several experts look at the contest forms and the models and advise you how make improvements to both to get you more points. I will have extra contest forms available at the meet.

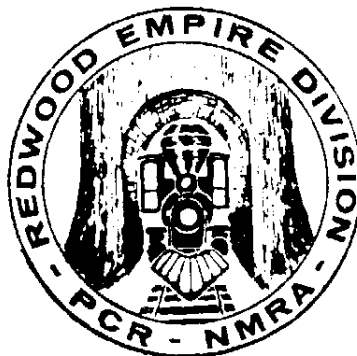

# THINK SMALL

## THE THIRD HAND

How often have you said, "I need three hands to do this"?" Once we advance from the simplest of kits we need help to hold stuff while the glue dries. When soldering is involved, you soon learn that fingers are a poor choice for holding bits of metal in place. We need clamps but the local hardware store does not stock the tiny clamps we seek. (Not wholly true but save that for now.) Any hobby shop for modelers of ships, airplanes, trucks or trains will have some good offerings in the way of small clamps. This is a good place to start. The smart modeler soon collects a variety of clamping devices.

If you share my frustrations, we have a common problem. Many times our collection of clamps is not quite adequate for the job at hand. A common household device, the spring clothespin, may save the day. It is cheap, available at the local hardware or super market and easy to modify. (Do not steal from your wife's collection - such conduct may be DANGEROUS !)

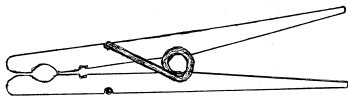

You probably know about the most common modification, the 180 degree rotation of the spring that yields a more versatile clamp.

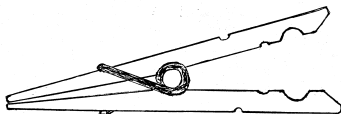

On the back of my workbench is a 2 inch by 6 inch chunk of 3/4 inch pine with the other common modification of the clothespin glued and pinned in place.

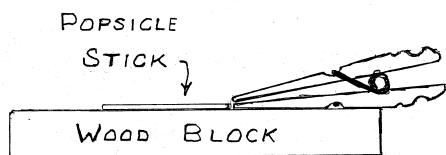

One use is for holding bits of styrene for welding with MEK.

Last fall another clothespin contraption took shape. I needed a third hand to hold the trolley wire while I relearned how to string overhead wire above HO track.

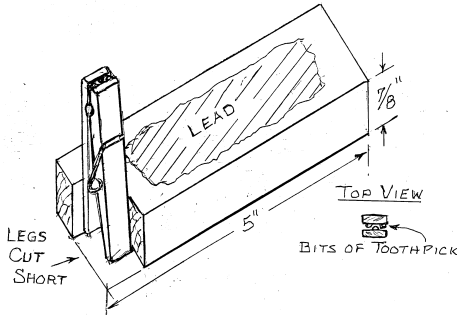

After I cut a big hollow in the wood block and poured in about a pound of lead, the device proved itself to be the dependable THIRD HAND I needed to complete the job.

You may find other uses for the common clothespin. Take care, improvising can be habit forming but you will smile. THINK SMALL, my collection even includes doll size spring clothespins just one inch long. Sometimes they are just the right size.

Do you want a tiny clamp built of durable steel? Years ago my girl children exposed me to clips for pin curls. Though only 1-3/4 inches long and gentle of grip, I find many uses for the small and shiny members of my clamp collection.

I bought a whole box full for not much

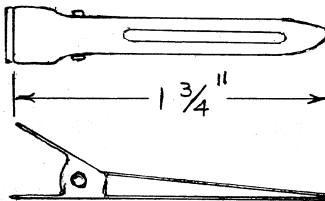

money at a beauty supply store. That was many years ago but I suspect similar clips are available today. The little rascals can be bent or cut at the tip for special jobs. Solder does not stick to the plated steel. Being small and thin, they steal very little heat when you are soldering close by. The clip proved its worth when I was hanging trolley wire. Remember the bead hangers from Trol-

ley III ?  
A clip held the hanger and trolley wire

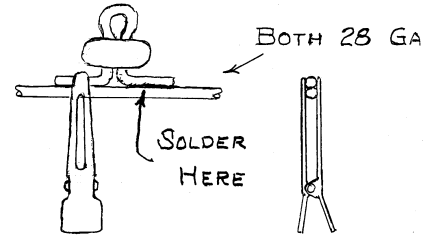

in alignment while I made the solder joint on one leg. Then it was a simple matter to apply a heat sink to keep the completed junction cool while I soldered the other leg.

Heat sinks come in many sizes and shapes. I'm talking about the little aluminum gadgets electronic folks use to avoid frying their magic devices while soldering connections. Every once in a while mine does double duty as an ordinary clamp.

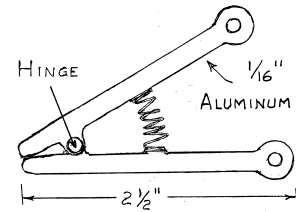

When you THINK SMALL this world has a barrel of offerings to solve problems that pester a hobbyist. Just keep an open mind. Solutions to puzzles crop up in surprising places. Example: Two popsicle sticks and a rubber band make a clamp with a long reach that is easily adapted to many tasks, even some that are impossible if you limit your choice to the commercial products.

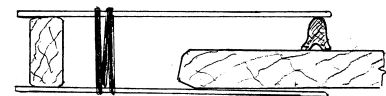

Enough for now. There is dust on the layout. I'm off to find the glue and my tools.

**MEMBERSHIP REPORT**

BY GUS CAMPAGNA

First I'd like to welcome BILL MUY-ALERT of Santa Rosa to the Redwood Empire Division. Bill, I look forward to meeting you at our next meeting. Next I'd like to thank my helpers at the Great American Train Show in San Rafael. STEVE SKOLD spent both days manning the booth and freeing me to set up my birthday dinner party. RON KAISER and BILL KAUFMAN also helped out on Saturday. We handed out information about our division and model railroading in general.

If we have an Apple Blossom Train Show (as of this writing I don't know), I'd like to have a table with members who would answer questions about model trains. If we could be working on a small project it might attract some interest. Let's talk about this at the Napa meeting. I'll bring along a sign up sheet for volunteers. GATS is coming back to San Rafael on May 15-16 and Vallejo on August 14-15. I will need helpers for both of these shows as well.

One final thought, bring along a friend to the next meet. Help show everyone what a good time we have at an RED meeting.

See you in Napa.

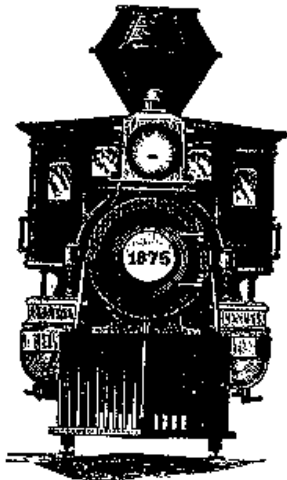

Many of the art items used in this newsletter are courtesy of Ken Houghton Rail Images or came from the website: [www.rrhistorical.com](http://www.rrhistorical.com)

**EDITOR'S NOTES:**

Future CALLBOARD schedules are as follows:

**April-June CALLBOARD**  
**Staff Meeting:** 7 PM, April 13  
**Text Deadline:** April 20  
**Mailing:** April 27  
**Meeting:** May 16

**July-September CALLBOARD**  
**Staff Meeting:** 7 PM, June 29  
**Text Deadline:** July 13  
**Mailing:** July 20  
**Meeting:** August 8

**October- December CALLBOARD**  
**Staff Meeting:** 7 PM, October 5  
**Text Deadline:** October 12  
**Mailing:** October 19  
**Meeting:** November 7

Submit all articles, calendar items, classified, and/or comments to:

Editor, 240 Chase Street,  
 Sonoma, CA 95476  
 or send it by e-mail to:  
[jrolston@pacbell.net](mailto:jrolston@pacbell.net)

**Send address corrections to:**  
**PCR, 530 Fig Tree Lane**  
**Martinez, CA 94553**

**CLASSIFIED ADS**

This is where we run classified ads from members and non-members. There is no charge for Redwood Empire Division members to place an ad. Non-members will be asked to pay a nominal charge of \$2.50 for each 4 lines.

**N-Scale Collection For Sale**

Locos, cars  
 Track, turnouts, switch machines, track accessories  
 Structures, vehicles  
 (1) MRC Tech II 1500 power supply.

SASE for list. Two stamps and I'll include some photos.

Harold Patton, 1358 Grand Terrace  
 San Rafael, CA 94901

**So Many Kits ...**

BY JOHN ROLSTON

An editorial in the February 2003 *FineScale Modeler* magazine really struck home with yours truly:

*We can now scientifically confirm that modelers are a happy bunch. In my November Editor's Page, I proposed that a modeler's optimism could be measured by how many unbuilt kits he has. Well, the results of my survey on that proposition are in. Of 1,120 responses, 218 modelers reported having between 1 and 10 unbuilt kits. Nearly a majority, 542, said they have 11 to 100 kits. Members of a substantial minority of 271 are carrying an inventory of 101 to 500. Forty-seven admitted owning 501 to 1,000, and 42 confessed in the privacy of this survey to possession of more than 1,000 kits. ...*

*Perfectly sensible reasons for amassing ridiculous numbers of unbuilt kits were reported:*

- \*You made good deals at swap meets.*
- \* You have to buy good kits when they're available.*
- \*Interest areas change.*
- \*You don't have enough room to display built models.*
- \* Family and jobs are too demanding just now to allow building, but you still enjoy buying. ...*

*But there is reason for concern. The reader who voted, then immediately begged: "Please don't tell my wife!" clearly has some relationship issues..*

*But perhaps the best reason reported for collecting still another kit was the simplest: "I don't have that one yet."*

Yours truly is with the majority. Which group are you in?

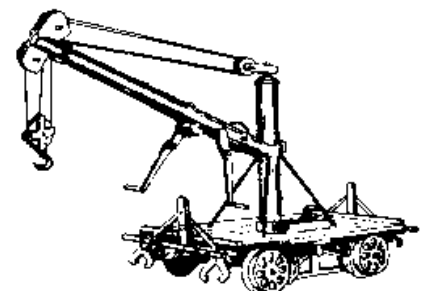

## NAPA VALLEY '04 PCR CONVENTION BY HAROLD MENTZER

The 2004 PCR Convention, the Pacific Coast Region's 60th birthday bash, will be held April 28-May 2 in Napa, at the Embassy Suites, hosted by the Napa Valley Model Railroad Historical Society and the Redwood Empire Division. A full program of model railroading will be available, guaranteed to keep the conventioneer busy throughout the convention.

JIM PROVIDENZA has prepared an exciting list of clinics, featuring well known local and nationally known presenters. If you are new to conventions, clinics are workshops and seminars on various aspects of model and prototype railroading. Clinics will be held Wednesday through Saturday in the morning, afternoon, and evening. Jim has worked hard to bring you a balanced array of modeling subjects. Also planned are Layout Design SIG (Special Interest Group) and Operation SIG workshops.

Under the direction of STEVE SKOLD, there will be a full schedule of contests, including model, photo and switching. For more information or entry forms, contact Steve; his address, etc. is listed on page 2.

ED ZAKARECKIS has lined up some great Prototype Tours, including the Napa Pipe Co. railcar loading facilities (featuring lots of prototype possibilities); a tour of the California Northern Rwy. yards at Napa Jct. (a fascinating little shortline); the Napa Valley Wine Train maintenance and restoration shops; and a special Wine Train champagne dinner on a Vista Dome car run up the Valley.

Layout Tours have been assembled by PAT WATKINS featuring home and club layouts throughout the area. Tours will visit some of the outstanding layouts in Marin County one evening, Sonoma County the next, and Napa & Solano Counties the following night. Some layouts will also be open on Sunday. Non-Rail Tours and activities will also be available under the direction of MARY

## MOORE-CAMPAGNA.

The Napa Valley '04 Convention Car is a custom built and finished HO **Accurail** Trailer Train Flatcar with the distinctive aqua color Napa Pipe load, including custom laser cut wood pipe bunks and prototypical strapping. Ready to run, less couplers, and all individually numbered, the cars and loads have been specially produced by the Napa Club members for the Napa Valley '04 Convention. The cars are priced at \$25.00 each, plus tax.

Registration for the Napa Valley '04 Convention, in advance or at the door, is: Full Fare Adult \$65.00

Day Fare Adult 35.00

Youth Fare 30.00

Non Rail Fare 25.00

For more registration information and forms, contact GUS CAMPAGNA at: Napa Valley '04, PO Box 758, Soda Springs, CA 957228, or phone (415) 990-3777, fax (530)426-9530 or email [campgus@earthlink.com](mailto:campgus@earthlink.com). A registration form is printed in the latest PCR *Branch Line* newsletter.

The convention site is the Embassy Suites Napa Valley Resort, 1075 California Blvd., a block east off Hwy. #29 at the First St. exit in Napa. Rates per day, for a comfortable spacious two room suite including a cooked to order breakfast and an afternoon complimentary cocktail hour, are for single or double occupancy: \$154.00; triple occupancy: \$174.00. The facility also offers an indoor pool sauna and an exercise room. To reserve rooms, phone (707) 253-9540, fax (707)253-9202, or email [www.embassynapa.com](http://www.embassynapa.com). These are special rates, so be sure to state that you are with the PACIFIC COAST REGION/NMRA.

Come join us for the Region's birthday party, and who knows, you may come away with something that will enhance your enjoyment of the hobby.

## GOODBYE TO A FRIEND...

On November 29, 2003 we all lost a very good friend. PAUL CHRISTENSEN passed away as the result of injuries received in an accident a few weeks before. I knew that I would be tasked to write some thoughts on this occasion and I have given it a great deal of thought. I could write about the sadness of loss and empty place in all our lives that Paul used to occupy but I will take the opportunity to write about how I remember him as a friend instead.

I met Paul in 1987 when I first became an active participant in RED activities. I remember his great smile and how he sought out a strange face at one of the RED meets in Rohnert Park. He tried to make me welcome and to find out a little about me. Over the years I worked with Paul on conventions, elections and meetings. I'd see him now and again and he always seemed the same; that is, he was having a good time. He really loved to be with other model railroaders and I think he had the most fun at conventions. He seemed to be all over the convention site at once. And every time he turned around he would run into someone else he knew. Most of those people were good enough friends to get one of those famous bear hugs.

Paul introduced me to a lot of people who are now my friends in model railroading as well. He also introduced me to fine scale modelers and their art. He was always interested in what the prototype groups were doing and seemed to be in touch with people all over the country. Paul could talk to anyone about almost any subject but trains were definitely his passion.

The last time I saw Paul was at the RED picnic in Fortuna this past summer. He was doing what he loved best; sharing his passion for trains with his friends. This photograph above was taken at the banquet in Fortuna.

I'll miss my friend and I'll cherish the memories.

Nolan Alexander



**Redwood Empire Garden Railway Society (REGRS)**, No. 1 gauge, various scales. If you are interested call Don Herzog (707) 823-3023 (please let the phone ring) or Terry Strom (707)526-0820 or e-mail [rrsteve@pacific.net](mailto:rrsteve@pacific.net)

**Napa Valley Model Railroad Club**, HO layout. Meets Fridays 7:30 PM at Napa Fairgrounds, 575 Third St., Napa. For information call: Clubhouse (707) 253-8428 or Ron Rogers (707)224-4040 or John Rodgers (707)226-2985. [www.nvmrc.org](http://www.nvmrc.org)

**Lake County Model Railroad Club**, HO layout; meets Tuesday at 7:00 PM in the old National Guard Building at the Lake County Fairgrounds on Martin Street, Lakeport. Call John Grutzmacher (707)279-8026 or Ron Zawerucha (707) 275-2875.

**Coastal Valley Lines**, HO modular. Meets 1st Thursday of the month at 7:00 PM at Sam's For Play Café, 2630 Cleveland Ave., Santa Rosa. Call Brad Squires (707) 568-4298 or Don Hanesworth 823-9615 <http://home.pacbell.net/jrolston/>

**Solano Rail Rats**, HO Scale For information call John Leins (707)422-8266

**Vallejo Model Railroad Club** meets

## CLUB SCHEDULES

each Wednesday and Friday evenings, at 7:00 PM in the Civic Building, Solano County Fairgrounds, 900 Fairgrounds Drive off I-80 and Hwy. 37, in Vallejo. Enter via Sage Street/Gate #1. The Club operates a HO scale layout. Information: (707)643-1809 (with answering machine) at the club.

**Sonoma County Model Railroad Society**. SCMRS is relocating. Contact Dave Gibbons at (707)526-2057.

**Humboldt Bay & Eureka**, HO layout, Eureka, CA. Contact David Berriman, P. O. Box 915 Arcata, CA 95518. (707)825-7689.

**Bay Area S Scalers**. Contact Lee Johnson at (925)943-1590.

**North Coast Narrow Gaugers** [www.ncng.org](http://www.ncng.org)

**NPC Operators** An On3 operating group meets one Sunday each month. Contact Steve Skold (707)539-1782 or e-mail [SandCSkold@aol.com](mailto:SandCSkold@aol.com)

**Mendocino Coast Model Railroad & Historical Society**, a Fort Bragg area group that promotes the hobby of model railroading. Construction under-

way of a historically accurate layout depicting the California Western (Skunk) from Ft. Bragg to Willits. Contact Philip Miller at (707)937-3605

**Redwood Empire Live Steamers**. A new group is forming with the goal to build a 7 1/2 inch track facility in a local park. For information, call Ann or Don at (707)578-4414 or write to PO Box 4594, Santa Rosa, CA 95402 [www.santarosals.org](http://www.santarosals.org)

**North Coast Live Steamers**, a group, from the Fort Bragg-Willits area, that promotes the hobby of large-scale railroading and other steam related history. Contact Bill Shepard at (707)961-0329.

**Eel River Valley Model Railroaders**, HO Scale layout. Meets each Friday evening at 7:30 P.M. at the Humboldt Co. Fair Grounds, Ferndale, CA. Write to P O Box 950 Fortuna CA 95540 or contact Ron Plies at (707)725-9063 or [rplies@cox.net](mailto:rplies@cox.net) for more information. [www.eelrivervalleyrr.org](http://www.eelrivervalleyrr.org)

**O Scale Modular Group** is forming in Santa Rosa. Contact Don Clauder at (707)539-3510



MEMBERSHIP APPLICATION 1/03  
 REDWOOD EMPIRE DIVISION (RED)  
 PACIFIC COAST REGION (PCR)  
 NATIONAL MODEL RAILROAD ASSOCIATION (NMRA)

LAST NAME: \_\_\_\_\_ FIRST NAME: \_\_\_\_\_

ADDRESS: \_\_\_\_\_

CITY: \_\_\_\_\_ STATE: \_\_\_\_\_ ZIP: \_\_\_\_\_

TELEPHONE #: \_\_\_\_\_ NMRA # (if a member): \_\_\_\_\_

I want to become a member of the Redwood Empire Division in the Pacific Coast Region of the NMRA. I have checked below the type of membership I desire and have enclosed the proper amount in a check payable to PCR-NMRA. I understand that membership in the RED/PCR requires membership in the NMRA.

- |  |   |
|--|---|
| <input type="checkbox"/> RED/PCR and NMRA for one year at \$51.00  | <input type="checkbox"/> RED/PCR only (requires NMRA membership # above) at \$6.00  |
| <input type="checkbox"/> RED/PCR and NMRA for five years at \$240.00   | <input type="checkbox"/> RED/PCR only five years (requires NMRA # above) at \$25.00 |
| <input type="checkbox"/> RED/PCR and NMRA affiliate at \$29.00<br>(No NMRA monthly <i>Bulletin</i> magazine) | <input type="checkbox"/> Check here if this is a renewal PCR #: _____               |
| <input type="checkbox"/> RED/PCR and NMRA Youth (under age 20 ) at \$36.00<br>Date of Birth: _____           |   |

Life memberships in both the NMRA and RED/ PCR are available. Contact Member Services Chairman for actuarial quote. Send application form and remittance to : PCR Member Services, 530 Fig Tree Lane, Martinez, CA 94553. Please allow 3-6 weeks for processing your application.

---



---

## COMING DOWN THE LINE



### COMPLEMENTARY COPY?

A complementary copy of this CALLBOARD issue is being mailed to all NMRA members who do not belong to the Redwood Empire Division (RED) and Pacific Coast Region (PCR). Also, complimentary copies are distributed to others to keep them up-to-date on local model railroading news and information. If the CALLBOARD issue you are reading is stamped **Complimentary Copy** in the mail label area below, please consider joining the RED (which includes the PCR), and the NMRA if required. A membership application is printed on page 7 and can be used for new members and renewals.

- February 8: **Redwood Empire Division** meet in Napa. Details on page 1.
- March 1: **Coast Division** meeting at Buscher Middle School, Santa Clara.
- March 13: **Sierra Division** meet and banquet in Sacramento. Contact Dick Witzens at [witzrr@cs.com](mailto:witzrr@cs.com) or (916)966-4592.
- March 20-21: **Coast Division** layout tours. Get maps at Coast Division meet.
- April 24& 25: **Train Show** sponsored by RED at the Apple Blossom Festival in Sebastopol.
- May 1 & 2: **Coastal Valley Lines** train show at Day Under The Oaks, Santa Rosa Jr. College, Santa Rosa
- April 28 - May 2: **Pacific Coast Region Annual Convention** in Napa. See page 6.
- May 16: **Redwood Empire Division** operating session at the Vallejo MRC layout.
- July 4 -11: **NMRA National Convention** in Seattle, WA
- August 8: **Redwood Empire Division** picnic, location TBD.
- November 7: **Redwood Empire Division** meet in Santa Rosa.

If your club has an event coming up, contact the Editor for inclusion in this list.

Visit RED at Website: <http://home.earthlink.net/~campgus/>

## CALLBOARD

John Rolston, Editor  
240 Chase Street  
Sonoma, CA 95476

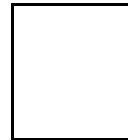

## FIRST CLASS