



# INSTALLATION INSTRUCTIONS

Description: **Brake Union Covers**

Part Number: **990A0-73006**

Applications:

Installation Time: **.20 HRS**

## Contents

Ref.	Part Number	Description	QTY
1.		Brake Union Cover	2
2.		O-Ring	2

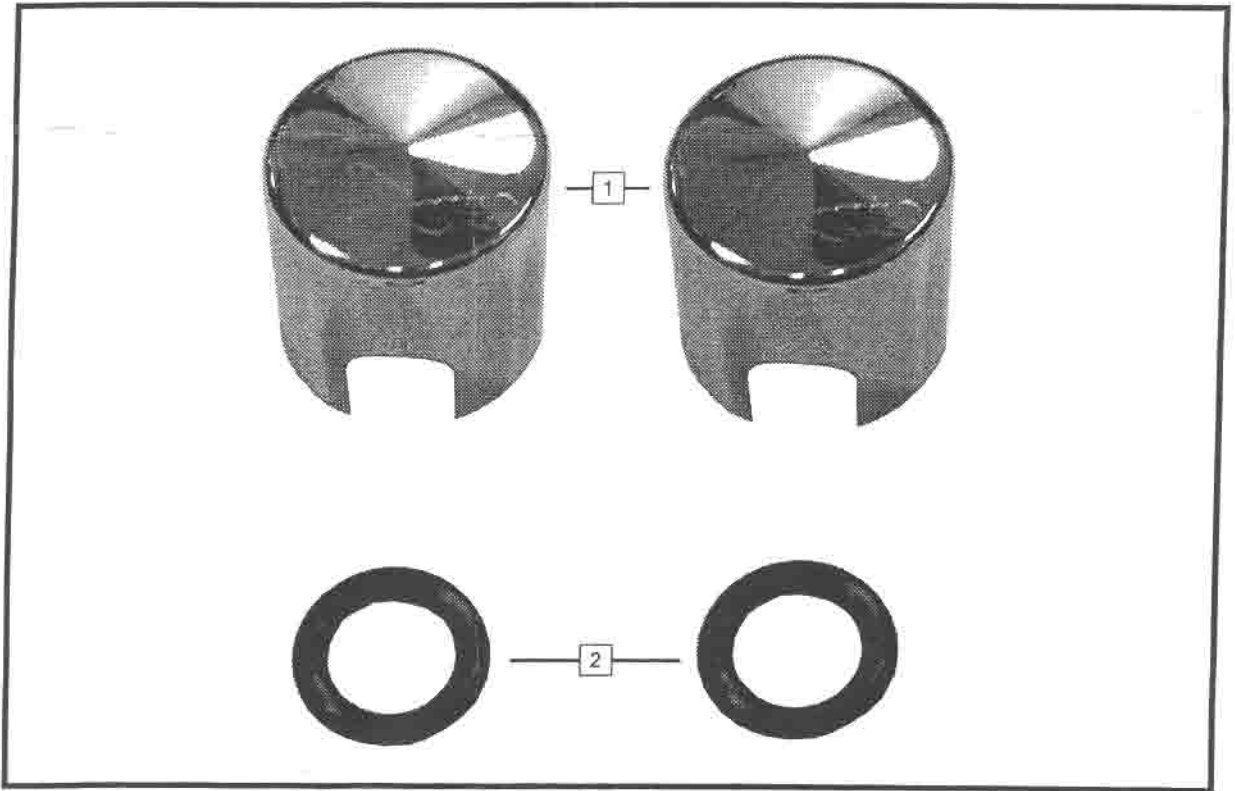

## Tools Required

Ref.	Tools Description
1.	WD40 or Liquid Soap

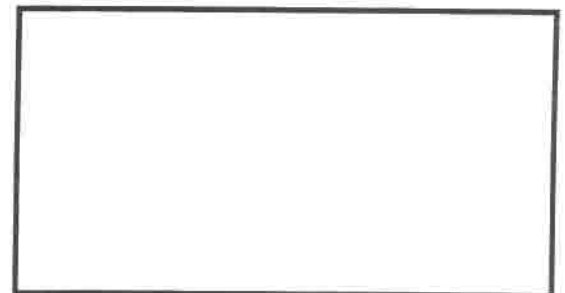

## Important

### ⚠ WARNING

Please read this manual and follow its instructions carefully. To emphasize special information, the symbol ⚠ and the words **WARNING** and **NOTE** have special meanings. Pay special attention to the messages highlighted by these signal words:

**NOTE:** Indicates special information to make maintenance easier or instructions clear.

### ⚠ WARNING

Indicates potential hazard that could result in death or injury.

## Preparation Prior to Installation

Please read and understand these instructions completely before installation to avoid any possible injury to yourself or damage to the motorcycle and/or accessory.

**NOTE to DEALER:** These instructions contain important information for future reference and must be given to the customer.

## Installation

1. Place one provided o-ring over the brake union bolt. See Figure #1.
2. Using WD-40 or liquid soap, lubricate the inside of one brake union cover. Slide the cover over the brake union bolt and o-ring. Be sure to line up the notch in the brake union cover with the brake line.
3. Repeat the previous steps for the opposite side.

